

BIKE  
SHELTER



## VERNON Shelter

### + FEATURES

- Unique and modern shape
- High robustness
- Vandal-resistant
- Unobtrusive landscape integration
- Available lengths: 4, 8 and 12 m

### ▾ OPTIONS

- Lighting
- Litter bin
- Bike racks
- E-bike charging points

*One-sided*



*Two-sided*





# VERNON Shelter

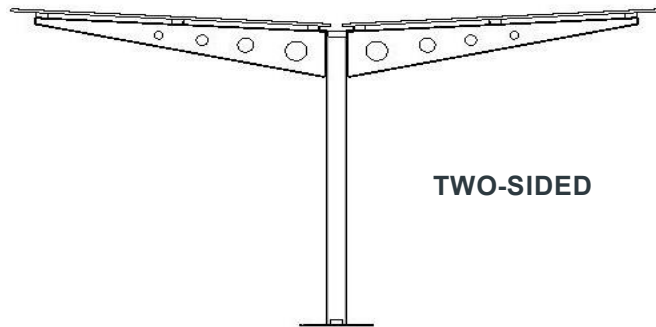

TWO-SIDED

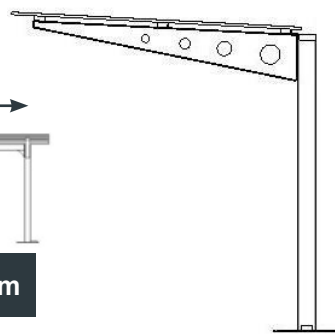

ONE-SIDED

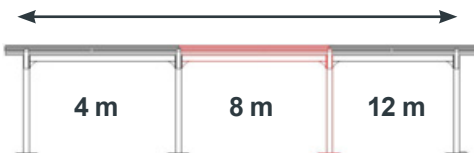

Available lengths: 4m, 8m and 12m

*Bike racks not included.*

*5-year warranty, except in case of vandalism, accident or storm (wind>130km/h)*

## SINGLE TWO-SIDED SHELTER

Length : 4,00 m  
Width : 4,50 m  
Height : 2,45 m



## SINGLE ONE-SIDED SHELTER

Length : 4,00 m  
Width : 2,50 m  
Height : 2,45 m



## CONSTRUCTION

- Galvanized steel tube frame
- 140x140x3mm square posts
- 140x140x3mm central crossbar
- Roof crossbar made of 80x40x3mm steel tubes
- Gutters capturing stormwater in the posts
- Welded beams, 8 mm thick
- Screws made of class-A2 stainless steel

## ROOF

- Anti-UV treated alveolar polycarbonate, 16mm thick.

## FINISH

- Polyester thermosetting paint, heated at 200°C, UV-resistant.
- Colour to be chosen within the RAL colour chart

## CAUTION

- This shelter does not include adjustable feet. To enable the mounting of the shelter, the floor must be perfectly flat and on the level ground.  
The shelter must be mounted on concrete blocks

## FIXING

- Pre-assembled anchoring devices that must be integrated in 1200 x 1200 x 700mm concrete blocks.

**Other possible dimensions. For any quotation or information request : +33 240 325 160**

**abri-plus.com**

31, rue de l'Industrie ■ B.P.38 ■ 44310 St-Philbert-de-Grand-Lieu ■ France  
Tél : 02 40 78 08 08 ■ Email : info@abri-plus.com

**abriplus**