

# Product specification

## B2MinckCharge

*Single-sided and Double-sided*

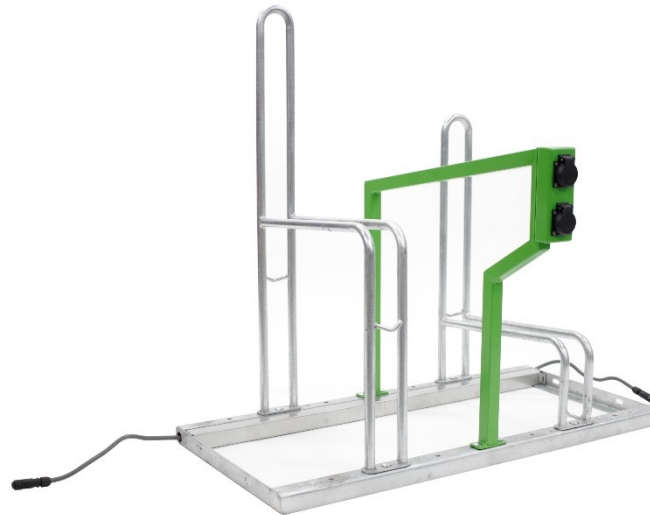

**Mobiliteitsoplossingen - Mobility Solutions - Mobilitätslösungen - Solutions de Mobilité**

Gansoord 80 | 2165 BD Lisserbroek (NL) | T: +31-(0)252-420384 | [www.lo-minck.nl](http://www.lo-minck.nl) | [info@lo-minck.nl](mailto:info@lo-minck.nl)  
KvK: 77815092 | BTW: NL861156687B01 | BIC: RABONL2U | IBAN: NL95RABO 0328101524 | SC: 990260 | EORI: 861156687  
Op al onze offertes, op alle opdrachten aan ons en op alle met ons gesloten overeenkomsten zijn de Metaalunie-voorwaarden van toepassing, gedeponereerd ter Griffie van de Rechtbank te Rotterdam, volgens de laatste aldaar neergelegde tekst. Deze leveringsvoorwaarden worden u op verzoek toegezonden.

## B2Minck

### *Comfort for bike ánd cyclist!*

**B2Minck** is a traditional single-layer bicycle rack, which is available with both single-sided and double-sided parking spaces.

**B2Minck** has the following unique characteristics:

- Spacious center distance (40cm) or generous center distance (50cm)
- Suitable for thin (from 22mm) and wide bicycle tires (up to 65mm)
- Provides stable parking position for 26", 28" and 29" tires
- Easily accessible locking device (RAL7016)
- Smart design prevents damage to brake discs
- Comfortable and stable storage place for crate bikes
- Single-sided and double-sided parking places
- Modular
- Value for money

### **B2MinckCharge**

- **B2Minck** with integrated charging points in locking device (RAL6018)
- Single sided: 2 charging points
- Double sided: 4 charging points
- Simple electrical connection via plug-and-play connectors (IP66)
- High-quality cable trays



## **Mobiliteitsoplossingen - Mobility Solutions - Mobilitätslösungen - Solutions de Mobilité**

Gansoord 80 | 2165 BD Lisserbroek (NL) | T: +31-(0)252-420384 | [www.lo-minck.nl](http://www.lo-minck.nl) | [info@lo-minck.nl](mailto:info@lo-minck.nl)  
KvK: 77815092 | BTW: NL861156687B01 | BIC: RABONL2U | IBAN: NL95RABO 0328101524 | SC: 990260 | EORI: 861156687  
*Op al onze offertes, op alle opdrachten aan ons en op alle met ons gesloten overeenkomsten zijn de Metaalunie-voorwaarden van toepassing, gedeponeerd ter Griffie van de Rechtbank te Rotterdam, volgens de laatste aldaar neergelegde tekst. Deze leveringsvoorwaarden worden u op verzoek toegezonden.*

**Specification *B2MinckCharge* single-sided 400mm (B2M400C-S65)**

- 2 parking spots
- 2x230V sockets (*male* connector included)
- Dimension (DxWxH): 800x485x965mm
- Front wheel clamps and frame: galvanized steel
- Locking device: galvanized steel + powdercoating (RAL6018)
- Dimension outer carton: 1.020x600x200mm
- Weight: 16,5kg

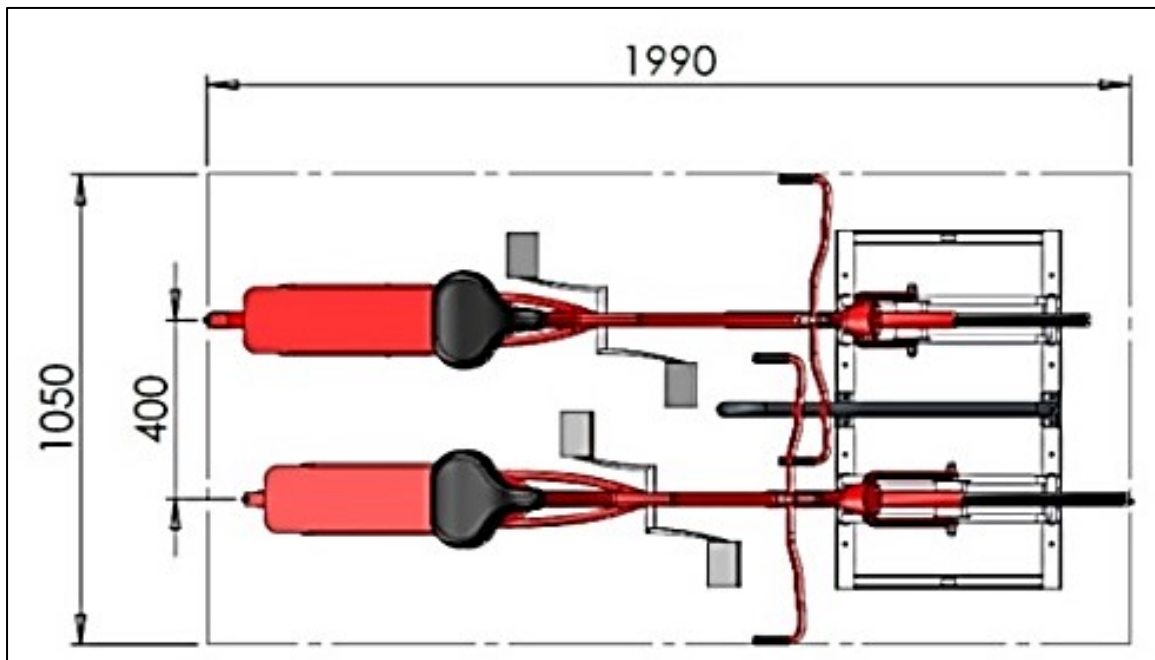
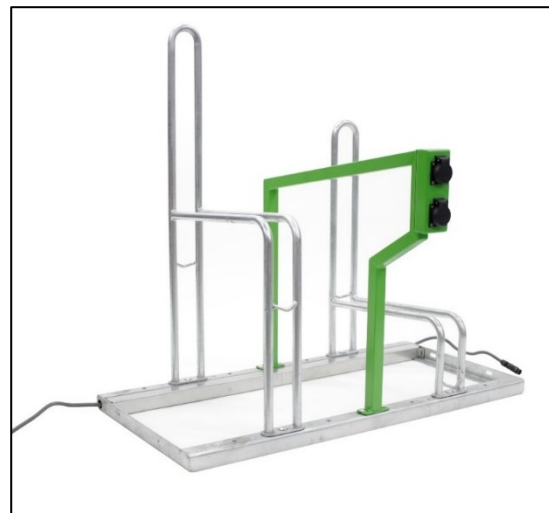
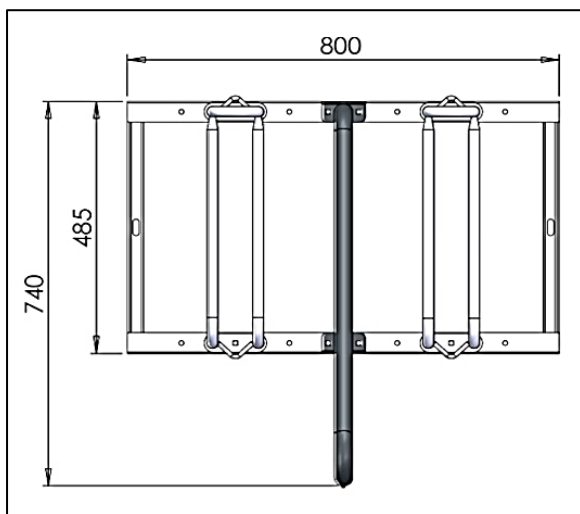

**Mobiliteitsoplossingen - Mobility Solutions - Mobilitätslösungen - Solutions de Mobilité**

Gansoord 80 | 2165 BD Lisserbroek (NL) | T: +31-(0)252-420384 | [www.lo-minck.nl](http://www.lo-minck.nl) | [info@lo-minck.nl](mailto:info@lo-minck.nl)  
 KvK: 77815092 | BTW: NL861156687B01 | BIC: RABONL2U | IBAN: NL95RABO 0328101524 | SC: 990260 | EORI: 861156687  
 Op al onze offertes, op alle opdrachten aan ons en op alle met ons gesloten overeenkomsten zijn de Metaalunie-voorwaarden van toepassing, gedeponeerd ter Griffie van de Rechtbank te Rotterdam, volgens de laatste aldaar neergelegde tekst. Deze leveringsvoorwaarden worden u op verzoek toegezonden.

**Specification *B2MinckCharge single-sided 500mm (B2M500C-S65)***

- 2 parking spots
- 2x230V sockets (*male* connector included)
- Dimension (DxWxH): 1.000x485x965mm
- Front wheel clamps and frame: galvanized steel
- Locking device: galvanized steel + powdercoating (RAL6018)
- Dimension outer carton: 1.020x600x200mm
- Weight: 17,5kg

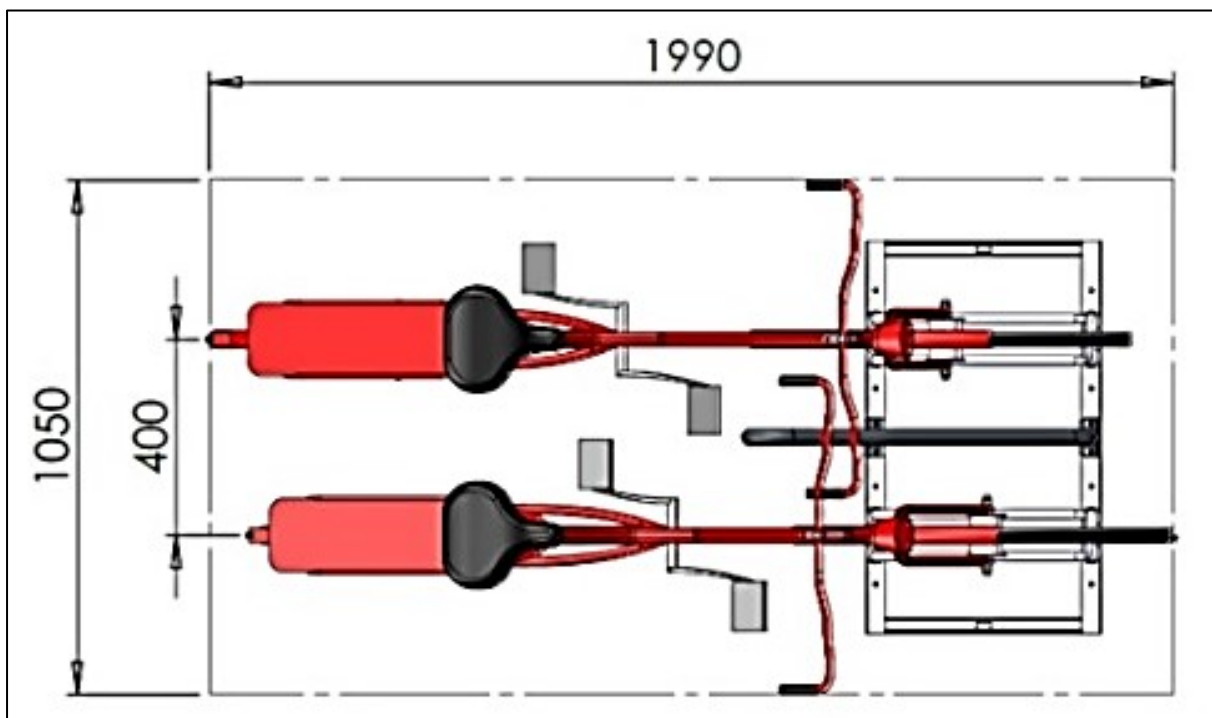
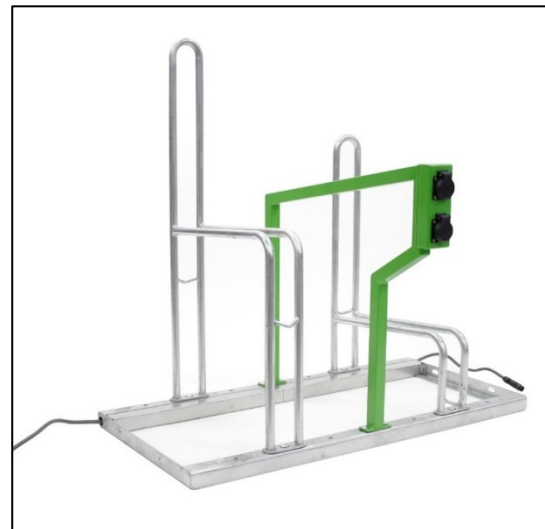
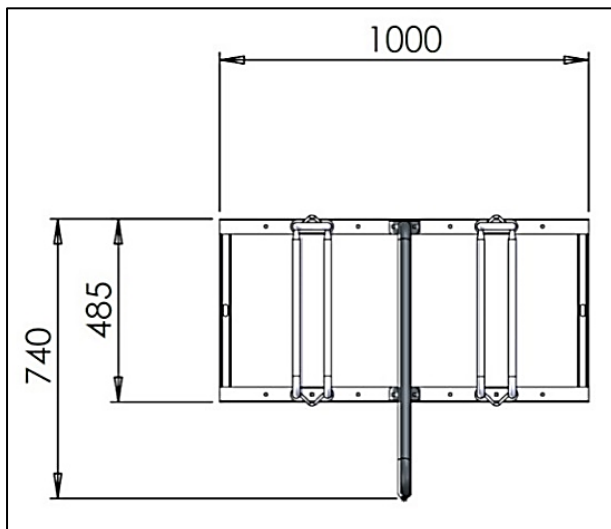

**Mobiliteitsoplossingen - Mobility Solutions - Mobilitätslösungen - Solutions de Mobilité**

Gansoord 80 | 2165 BD Lisserbroek (NL) | T: +31-(0)252-420384 | [www.lo-minck.nl](http://www.lo-minck.nl) | [info@lo-minck.nl](mailto:info@lo-minck.nl)  
 KvK: 77815092 | BTW: NL861156687B01 | BIC: RABONL2U | IBAN: NL95RABO 0328101524 | SC: 990260 | EORI: 861156687  
 Op al onze offertes, op alle opdrachten aan ons en op alle met ons gesloten overeenkomsten zijn de Metaalunie-voorwaarden van toepassing, gedeponneerd ter Griffie van de Rechtbank te Rotterdam, volgens de laatste aldaar neergelegde tekst. Deze leveringsvoorwaarden worden u op verzoek toegezonden.

**Specification *B2MinckCharge double-sided 400mm (B2M400C-S65)***

- 4 parking spots
- 2x2x230V sockets (*male connector included*)
- Dimension (DxWxH): 800x485x965mm
- Front wheel clamps and frame: galvanized steel
- Locking device: galvanized steel + powdercoating (RAL6018)
- Dimension outer carton (DxWxH): 1.020x540x300mm<sup>1</sup>
- Weight outer carton: 19kg
- <sup>1</sup> *excl. double-sided locking device which is separately packed*
- Dimension outer carton double-sided locking device (DxBxH): 1.000x800x200mm
- Weight outer carton: 6kg

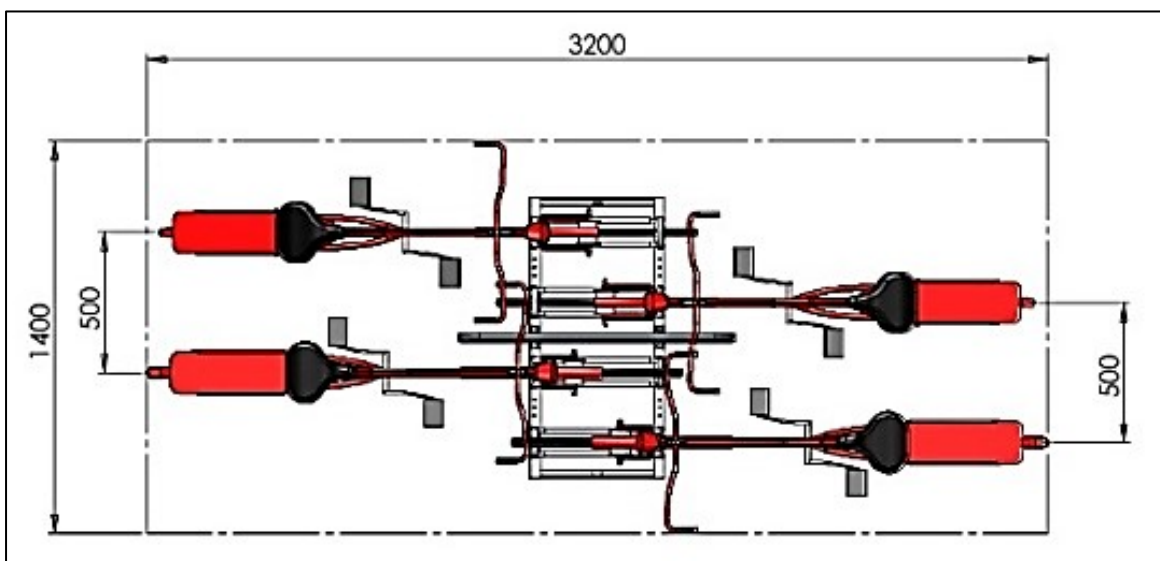
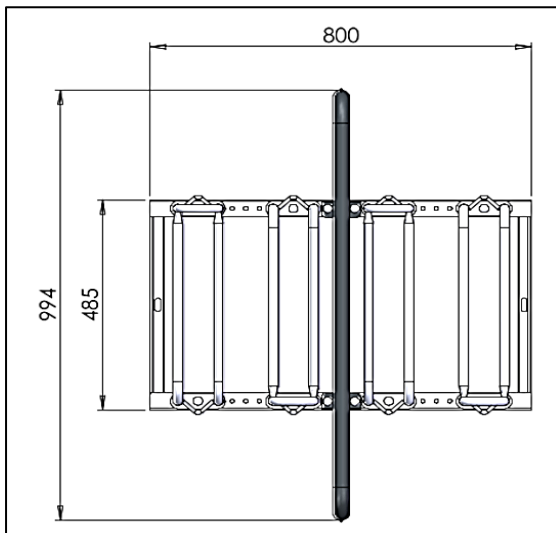

**Mobiliteitsoplossingen - Mobility Solutions - Mobilitätslösungen - Solutions de Mobilité**

Gansoord 80 | 2165 BD Lisserbroek (NL) | T: +31-(0)252-420384 | [www.lo-minck.nl](http://www.lo-minck.nl) | [info@lo-minck.nl](mailto:info@lo-minck.nl)  
 KvK: 77815092 | BTW: NL861156687B01 | BIC: RABONL2U | IBAN: NL95RABO 0328101524 | SC: 990260 | EORI: 861156687  
 Op al onze offertes, op alle opdrachten aan ons en op alle met ons gesloten overeenkomsten zijn de Metaalunie-voorwaarden van toepassing, gedeponeerd ter Griffie van de Rechtbank te Rotterdam, volgens de laatste aldaar neergelegde tekst. Deze leveringsvoorwaarden worden u op verzoek toegezonden.

### **Specification B2MinckCharge double-sided 500mm (B2M500C-S65)**

- 4 parking spots
- 2x2x230V sockets (*male* connector included)
- Dimension (DxWxH): 1.000x485x965mm
- Front wheel clamps and frame: galvanized steel
- Locking device: galvanized steel + powdercoating (RAL6018)
- Dimension outer carton (DxWxH): 1.020x540x300mm<sup>1</sup>
- Weight outer carton: 19kg
- <sup>1</sup> *excl. double-sided locking device which is separately packed*
- Dimension outer carton double-sided locking device (DxBxH): 1.000x800x200mm
- Weight outer carton: 6kg

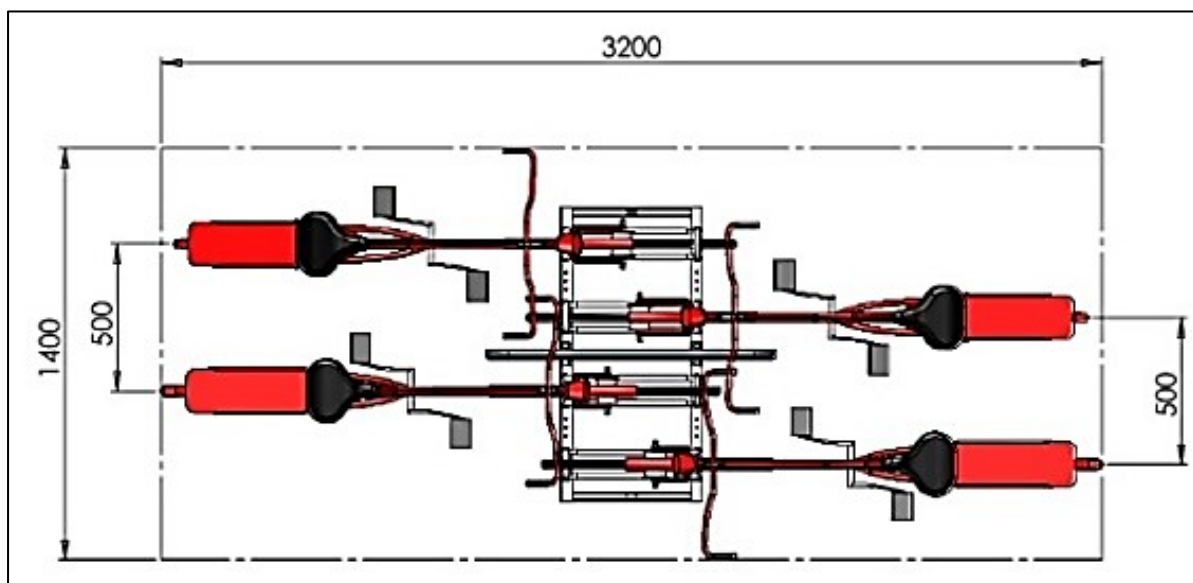
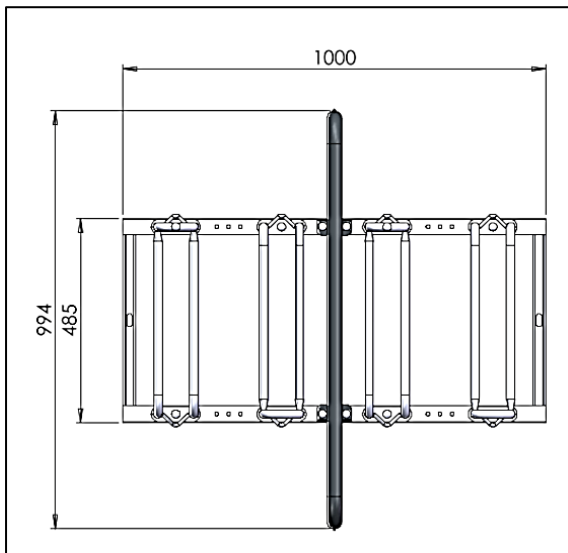

### **Mobiliteitsoplossingen - Mobility Solutions - Mobilitätslösungen - Solutions de Mobilité**

Gansoord 80 | 2165 BD Lisserbroek (NL) | T: +31-(0)252-420384 | [www.lo-minck.nl](http://www.lo-minck.nl) | [info@lo-minck.nl](mailto:info@lo-minck.nl)  
 KvK: 77815092 | BTW: NL861156687B01 | BIC: RABONL2U | IBAN: NL95RABO 0328101524 | SC: 990260 | EORI: 861156687  
 Op al onze offertes, op alle opdrachten aan ons en op alle met ons gesloten overeenkomsten zijn de Metaalunie-voorwaarden van toepassing, gedeponneerd ter Griffie van de Rechtbank te Rotterdam, volgens de laatste aldaar neergelegde tekst. Deze leveringsvoorwaarden worden u op verzoek toegezonden.

### Current

A common charger for a bicycle battery consumes 350W (approx. 1.5A). If the 2 or 4 sockets are all used at full power at the same time, this means a maximum power of resp. 700W (single-sided) and 1,400W (double-sided). **B2MinckCharge** is preferably connected to a separate group (230V/16A) based on the following maximum number of charging points per 230V/16A power supply group:

- 4x single-sided (8 charging points)
- 2x double-sided (8 charging points)



### Expansion modules

Several modules are linked together by means of high-quality waterproof couplings (IP66). The cables and couplings (can) be covered by galvanized cable covers to be ordered separately.

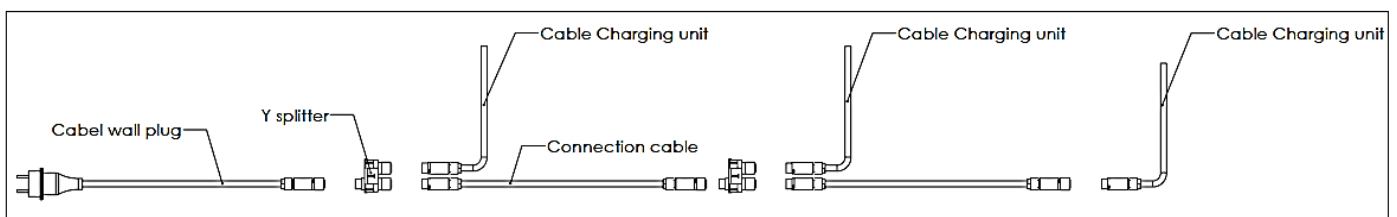
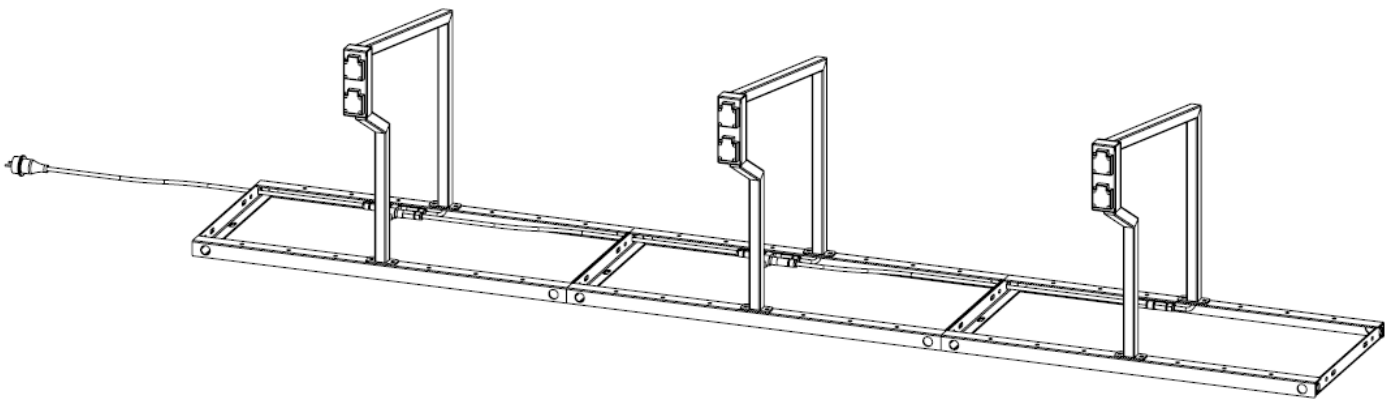

### **Mobiliteitsoplossingen - Mobility Solutions - Mobilitätslösungen - Solutions de Mobilité**

Gansoord 80 | 2165 BD Lisserbroek (NL) | T: +31-(0)252-420384 | [www.lo-minck.nl](http://www.lo-minck.nl) | [info@lo-minck.nl](mailto:info@lo-minck.nl)  
 KvK: 77815092 | BTW: NL861156687B01 | BIC: RABONL2U | IBAN: NL95RABO 0328101524 | SC: 990260 | EORI: 861156687  
 Op al onze offertes, op alle opdrachten aan ons en op alle met ons gesloten overeenkomsten zijn de Metaalunie-voorwaarden van toepassing, gedeponneerd ter Griffie van de Rechtbank te Rotterdam, volgens de laatste aldaar neergelegde tekst. Deze leveringsvoorwaarden worden u op verzoek toegezonden.

### Loose electrical components

The components below for electrically coupling the individual **B2MinckCharge** modules with each other are available separately.

- Female connector (IP66) with plug for 230V/16A (incl. 2m<sup>1</sup> cable)
  - <sup>1</sup> Extra cable available on request
- Female/Male connector incl. Y-coupling (IP66) for center distance 400mm (incl. 80cm cable)
- Female/Male connector incl. Y-coupling (IP66) for center distance 500mm (incl. 100cm) cable)



*Y-connector*



*Connectors for electric connection*



*Electric connection*

### Guarantee

- 6 months manufacturer's warranty (from delivery date)

## **Mobiliteitsoplossingen - Mobility Solutions - Mobilitätslösungen - Solutions de Mobilité**

Gansoord 80 | 2165 BD Lisserbroek (NL) | T: +31-(0)252-420384 | [www.lo-minck.nl](http://www.lo-minck.nl) | [info@lo-minck.nl](mailto:info@lo-minck.nl)  
KvK: 77815092 | BTW: NL861156687B01 | BIC: RABONL2U | IBAN: NL95RABO 0328101524 | SC: 990260 | EORI: 861156687  
*Op al onze offertes, op alle opdrachten aan ons en op alle met ons gesloten overeenkomsten zijn de Metaalunie-voorwaarden van toepassing, gedeponeerd ter Griffie van de Rechtbank te Rotterdam, volgens de laatste aldaar neergelegde tekst. Deze leveringsvoorwaarden worden u op verzoek toegezonden.*