

220/PL 600A



HYDRAULIC BOLLARDS WITH PUMP IN THE CONTROL UNIT

PILOMAT 220/PL 600A automatic bollards are the products with the best quality/price ratio of the hydraulic PILOMAT range. Current models are the result of the dedication of more than 40 years in the field of access control and a twenty-year specialization in bollards.

The installation of 220/PL 600A bollard is recommended for the management of: pedestrian areas, private parkings, business parkings, private driveways, business driveways, commercial driveways.

Customize your system with the several optionals available to obtain the most effective solution.



PAG.1/3

PILOMAT

100% MADE IN ITALY

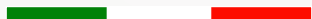

PILOMAT s.r.l.
www.pilomat.com / pilomat@pilomat.com
Via Zanica 17/p, 24050, Grassobbio (BG) Italy
Tel. +39.035.29.72.20
Copyright 2016© Pilomat S.r.l. All rights reserved

220/PL 600A_DATASHEET.16 REVIEW 09/05/2016

OPTIONAL ITEMS

PILOMAT BOLLARD 220/PL 600AFEV - NORMAL STEEL PAINTED

PILOMAT BOLLARD 220/PL 600AIXV - STAINLESS STEEL PAINTED

PILOMAT BOLLARD 220/PL 600AIXS - STAINLESS STEEL BRUSHED

PIT IN ALUZINC FOR PILOMAT 220/PL 600A - COUNTERFRAME AND BRACKETS
ONE PIT FOR EACH BOLLARD

CONTROL UNIT FOR PILOMAT 220/PL 600A

MULTILED FLASHING LIGHT- 8 LED POINTS

BUZZER ACOUSTIC SIGNAL FOR AUTOMATIC BOLLARDS

REFLECTING ADHESIVE STRIP - WHITE (NO-LOGO)

HEAD WITHOUT LOGO FOR PILOMAT 220/PL 600A

PAINTING WITH RAL COLOUR ON REQUEST

BIODEGRADABLE FUCHS OIL FOR HYDRAULIC PUMP

HEATING RESISTANCE FOR PILOMAT BOLLARDS - TRANSFORMER AND THERMOSTAT
ONE RESISTANCE FOR EACH BOLLARD

RADIO RECEIVER

RADIO TRANSMITTER TWO-CHANNEL

TRAFFIC LIGHT WITH TWO LIGHTS (GREEN-RED)

INDUCTIVE DETECTOR FOR LOOPS

INDUCTIVE LOOP - DIMENSION: 7,60m - 9,60m - 12,60m - LINE: 15m AND 30m

TIMER PROGRAMMER

INDUCTIVE CARD READER

LOCK SELECTOR

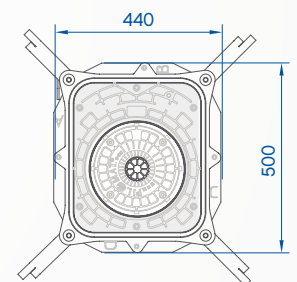
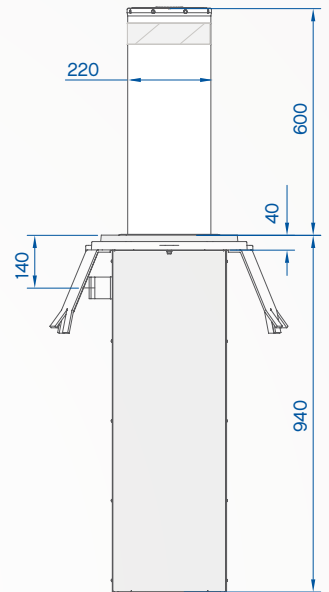

220/PL 600A



MOVING CYLINDER	NORMAL STEEL FE370 - AISI 304 STAINLESS STEEL
MOVING CYLINDER DIAMETER	220mm
MOVING CYLINDER HEIGHT	600mm
MOVING CYLINDER THICKNESS NORMAL STEEL	4mm
MOVING CYLINDER THICKNESS STAINLESS STEEL	4mm
MOVING CYLINDER NORMAL STEEL FINISH	POLYESTER POWDER PAINT - STANDARD GREY ANTHRACITE
MOVING CYLINDER STAINLESS STEEL FINISH	AS ABOVE OR BRUSHED
REFLECTING ADHESIVE STRIP	YES - HEIGHT 55mm
RISING SPEED	12cm/s
LOWERING SPEED	25cm/s
MANUAL EMERGENCY LOWERING	YES (ALSO FOR VERSION WITH AUTOMATIC LOWERING IF POWER FAILED)
SAFETY REVERSAL PRESSURE SWITCH	YES
CONNECTION LINE TO CONTROL UNIT	STANDARD 10m (MAX. LENGTH 20m)
VOLTAGE FOR CONTROL UNIT	230Vac (+/- 10%) 50/60Hz
HYDRAULIC PUMP	IN THE CONTROL UNIT
PROTECTION CLASS	IP67
TYPE OF USE	INTENSIVE - LIFE AVERAGE 3.000.000 MOVEMENTS - 2000 MOVEMENTS/DAY
IMPACT RESISTANCE (WITHOUT DEFORMATION)	30.000 J
BREAKOUT RESISTANCE	150.000 J
OPERATING TEMPERATURE	-40 °C +70 °C (FOR LOW TEMPERATURES SEE HEATING RESISTANCE)

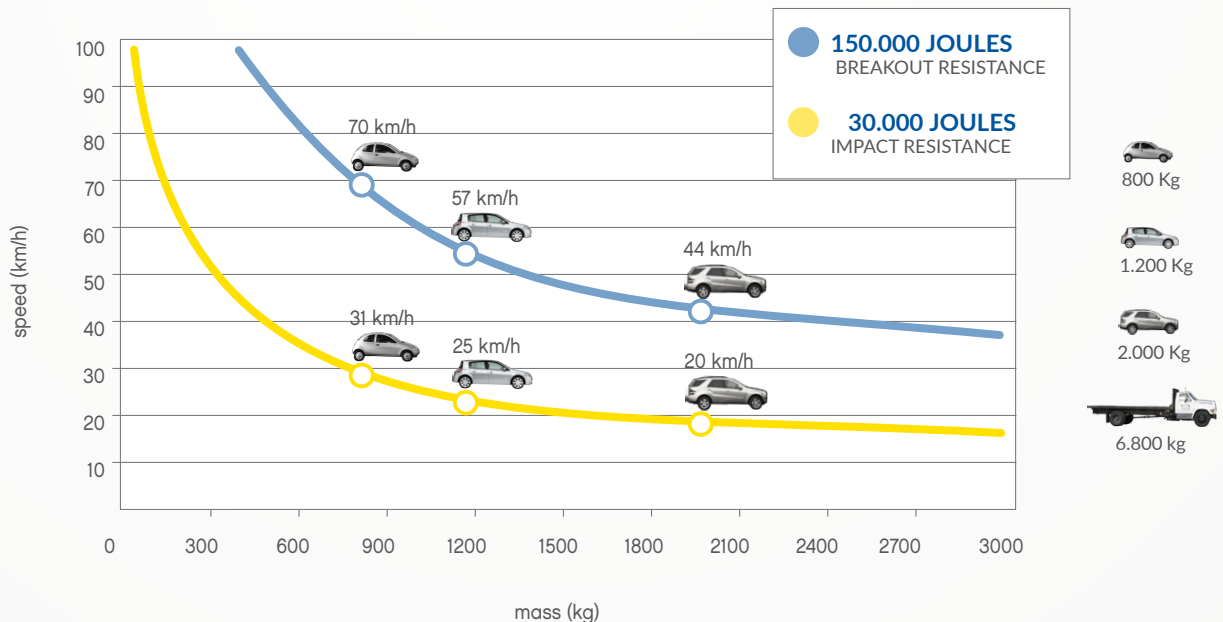

100% MADE IN ITALY

PILOMAT s.r.l.
 www.pilomat.com / pilomat@pilomat.com
 Via Zanica 17/p, 24050, Grassobbio (BG) Italy
 Tel. +39.035.29.72.20
 Copyright 2016© Pilomat S.r.l. All rights reserved