

220/PL 600SA



SEMI-AUTOMATIC BOLLARDS WITH GAS ACTUATOR

The semiautomatic bollard PILOMAT 220/PL 600SA with single gas actuator is designed and built with architectural appearance similar to that of the automatic PILOMAT bollards and therefore also allows the combined use of both versions. Current models are the result of the dedication of more than 40 years in the field of access control, and a twenty-year specialization in bollards.

GENERAL FEATURES

The Semiautomatic PILOMAT are used to define or prevent the stationing or transit of vehicles in pedestrian or private areas. Because of the procedure of parking, it is advised that the semi-automatic PILOMAT be used only if the amount of daily movements is limited.



PAG.1/3

PILOMAT

100% MADE IN ITALY



PILOMAT s.r.l.
www.pilomat.com / pilomat@pilomat.com
Via Zanica 17/p, 24050, Grassobbio (BG) Italy
Tel. +39.035.29.72.20
Copyright 2016© Pilomat S.r.l. All rights reserved

220/PL600SA_DATASHEET.16 REVIEW 02/07/2016

OPTIONAL ITEMS

PILOMAT BOLLARD 220/PL 600SAFEV - NORMAL STEEL PAINTED

PILOMAT BOLLARD 220/PL 600SAIXV - STAINLESS STEEL PAINTED

PILOMAT BOLLARD 220/PL 600SAIXS - STAINLESS STEEL BRUSHED

PIT IN ALUZINC FOR PILOMAT 220/PL 600SA - COUNTERFRAME AND BRACKETS / ONE PIT FOR EACH BOLLARD

MULTILED FLASHING LIGHT- 8 LED POINT

FLASHING LIGHT POWER CIRCUIT FOR SEMIAUTOMATIC BOLLARDS (MAX. 4 BOLLARDS)

HEAD WITHOUT LOGO FOR PILOMAT 220/PL 600SA

PAINTING WITH RAL COLOUR ON REQUEST

LOCK FOR TRIANGULAR KEY 11mm - 2 KEYS

LOCK FOR TRIANGULAR KEY 9mm - WITHOUT KEYS

KIT 5 TRIANGULAR KEYS 11mm FOR SEMIAUTOMATIC BOLLARDS

KIT 5 STANDARD KEYS FOR SEMIAUTOMATIC BOLLARDS

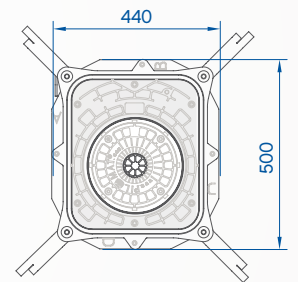
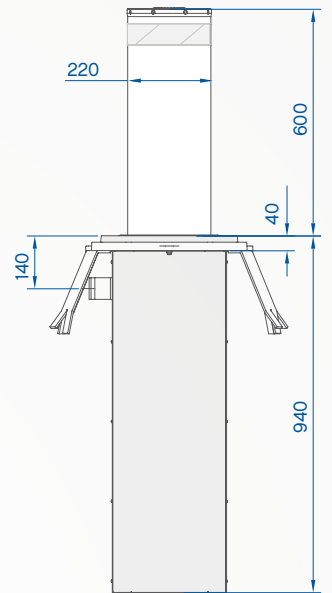

PILOMAT

100% MADE IN ITALY

220/PL 600SA



MOVING CYLINDER	NORMAL STEEL FE370 - AISI 304 STAINLESS STEEL
MOVING CYLINDER DIAMETER	220mm
MOVING CYLINDER HEIGHT	600mm
MOVING CYLINDER NORMAL STEEL THICKNESS	4mm
MOVING CYLINDER STAINLESS STEEL THICKNESS	4mm
MOVING CYLINDER NORMAL STEEL FINISH	POLYESTER POWDER PAINT - STANDARD GREY ANTHRACITE
MOVING CYLINDER STAINLESS STEEL FINISH	AS ABOVE OR BRUSHED
REFLECTING ADHESIVE STRIP	YES - HEIGHT 55mm
RISING SPEED	20cm/s
LOWERING SPEED	MANUAL
CONNECTION LINE TO CONTROL UNIT	STANDARD 10m (MAX. LENGTH 80m)
PROTECTION CLASS	IP67
IMPACT RESISTANCE (WITHOUT DEFORMATION)	30.000 J
BREAKOUT RESISTANCE	150.000 J
OPERATING TEMPERATURE	-40 °C +60 °C

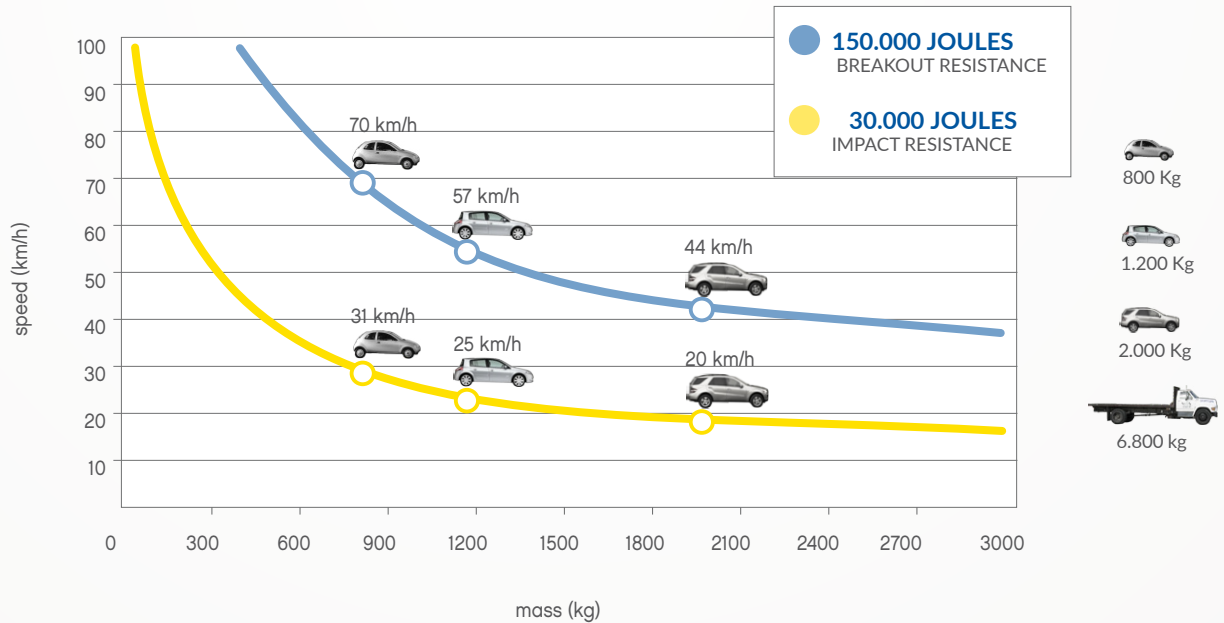

100% MADE IN ITALY

PILOMAT s.r.l.
 www.pilomat.com / pilomat@pilomat.com
 Via Zanica 17/p, 24050, Grassobbio (BG) Italy
 Tel. +39.035.29.72.20
 Copyright 2016© Pilomat S.r.l. All rights reserved