

# 275/P 600A



## HYDRAULIC BOLLARD WITH BUILT-IN PUMP

PILOMAT 275/P 600A automatic bollards are the top line products of the PILOMAT range. Current models are the result of the dedication of more than 40 years in the field of access control, and a twenty-year specialization in bollards. The installation of 275/P 600A bollard is recommended for the management of: pedestrian areas, private parkings, business parkings, private driveways, business driveways, commercial driveways.

Customize your system with the several optionals available to obtain the most effective solution.



## OPTIONAL ITEMS

PILOMAT BOLLARD 275/P 600AIXV - STAINLESS STEEL PAINTED
PILOMAT BOLLARD 275/P 600AIXS - STAINLESS STEEL BRUSHED
PIT IN ALUZINC FOR PILOMAT 275/P 600A - COUNTERFRAME AND BRACKETS ONE PIT FOR EACH BOLLARD
CONTROL UNIT FOR PILOMAT 275/P 600A
MULTILED FLASHING LIGHT- 27 LED POINTS
BUZZER ACOUSTIC SIGNAL FOR AUTOMATIC BOLLARDS
REFLECTING ADHESIVE STRIP - WHITE (NO-LOGO)
HEAD WITHOUT LOGO FOR PILOMAT 275/P 600A
PAINTING WITH RAL COLOUR ON REQUEST
BIODEGRADABLE FUCHS OIL FOR HYDRAULIC PUMP
HEATING RESISTANCE FOR PILOMAT BOLLARDS - TRANSFORMER AND THERMOSTAT ONE RESISTANCE FOR EACH BOLLARD
RADIO RECEIVER
RADIO TRANSMITTER TWO-CHANNEL
TRAFFIC LIGHT WITH TWO LIGHTS (GREEN-RED)
INDUCTIVE DETECTOR FOR LOOPS
INDUCTIVE LOOP - DIMENSION: 7,60m - 9,60m - 12,60m - LINE: 15m AND 30m
TIMER PROGRAMMER
INDUCTIVE CARD READER
LOCK SELECTOR

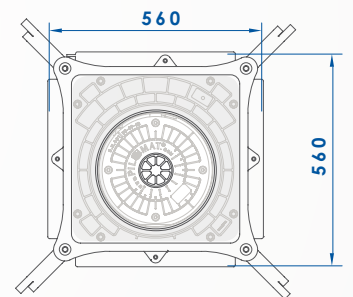
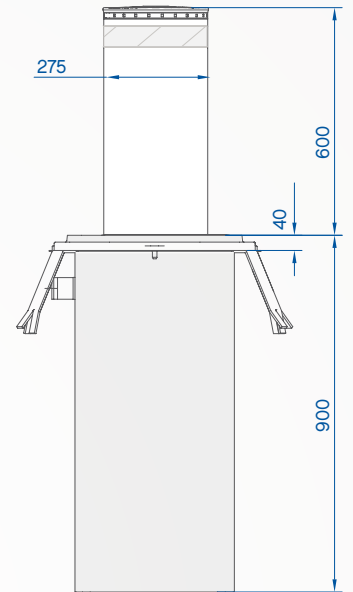

# 275/P 600A



MOVING CYLINDER	NORMAL STEEL FE370 - AISI 304 STAINLESS STEEL
MOVING CYLINDER DIAMETER	275mm
MOVING CYLINDER HEIGHT	600mm
MOVING CYLINDER NORMAL STEEL THICKNESS	6mm
MOVING CYLINDER STAINLESS STEEL THICKNESS	AISI 304: 6mm - AISI 316: 4mm
MOVING CYLINDER NORMAL STEEL FINISH	POLYESTER POWDER PAINT - STANDARD GREY ANTHRACITE
MOVING CYLINDER STAINLESS STEEL FINISH	POLYESTER POWDER PAINT - STANDARD GREY ANTHRACITE OR BRUSHED
OTHER MOVING CYLINDER FINISH	RIBS ON CYLINDER'S SURFACE
REFLECTING ADHESIVE STRIP	YES - HEIGHT 55mm
RISING SPEED	15cm/s
LOWERING SPEED	25cm/s
MANUAL EMERGENCY LOWERING	YES (ALSO FOR VERSION WITH AUTOMATIC LOWERING IF POWER FAILED)
SAFETY REVERSAL PRESSURE SWITCH	YES
CONNECTION LINE TO CONTROL UNIT	STANDARD 10m (MAX. LENGTH 80m - WITH HEATING RESISTANCE MAX. 50m)
VOLTAGE FOR CONTROL UNIT	230Vac (+/- 10%) 50/60Hz
HYDRAULIC PUMP	BUILT-IN THE BOLLARD
PROTECTION CLASS	IP67
TYPE OF USE	INTENSIVE - LIFE AVERAGE 3.000.000 MOVEMENTS - 2000 MOVEMENTS/DAY
IMPACT RESISTANCE (WITHOUT DEFORMATION)	40.000 J
BREAKOUT RESISTANCE	250.000 J
OPERATING TEMPERATURE	-40 °C +70 °C (FOR LOW TEMPERATURES SEE HEATING RESISTANCE)

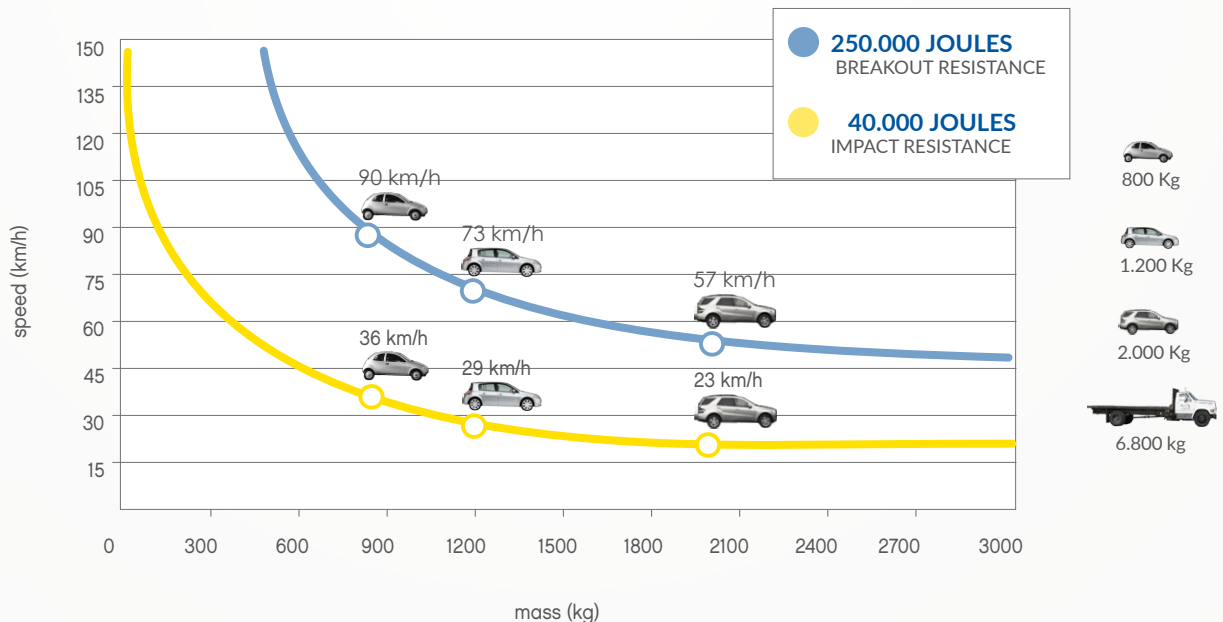

100% MADE IN ITALY

PILOMAT s.r.l.  
[www.pilomat.com](http://www.pilomat.com) / [pilomat@pilomat.com](mailto:pilomat@pilomat.com)  
 Via Zanica 17/p, 24050, Grassobbio (BG) Italy  
 Tel. +39.035.29.72.20  
 Copyright 2016© Pilomat S.r.l. All rights reserved