

Mouv'ROC

Technical file

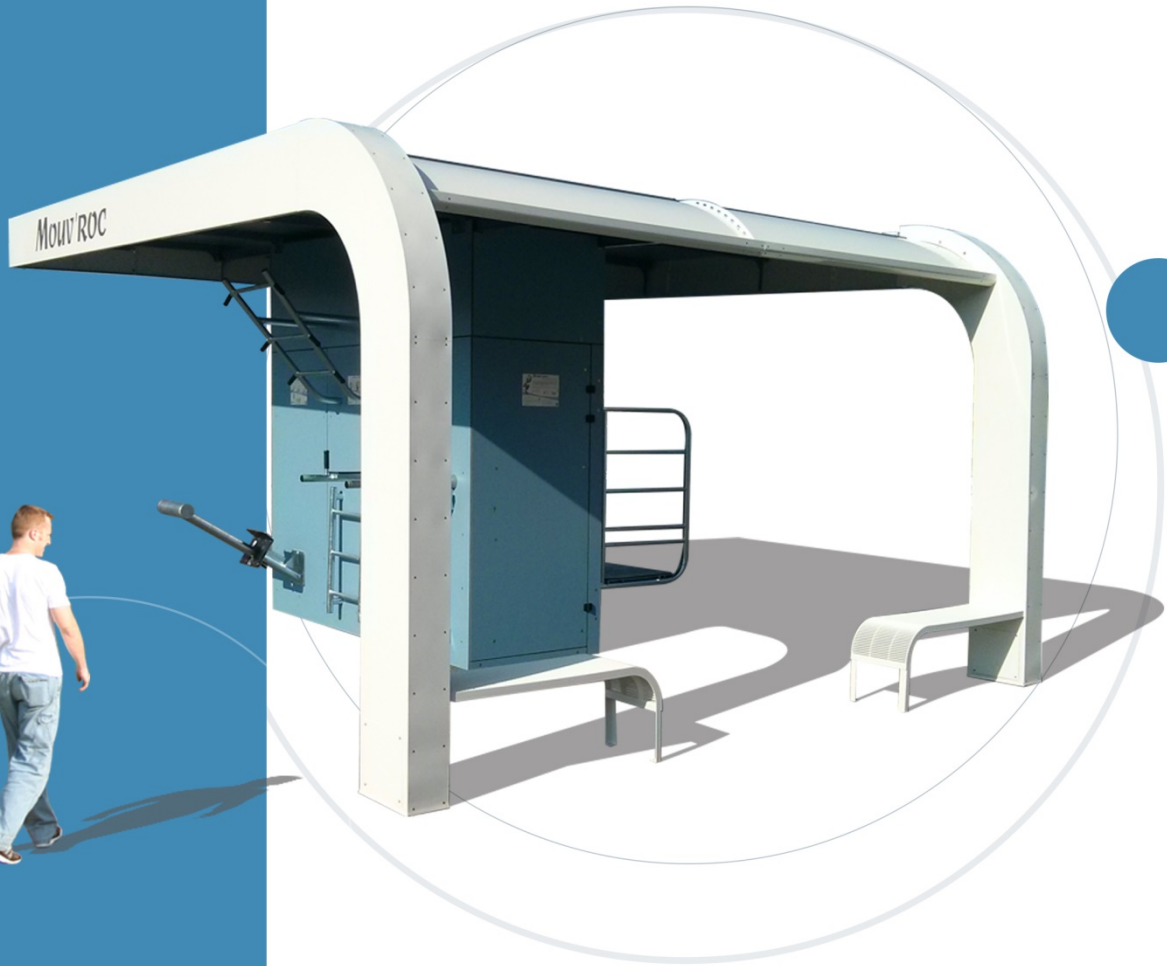

Sport Santé pour tous !

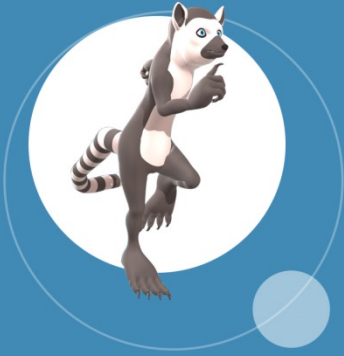

Contents

- Materials and surface treatments
- Solidity of the structure / Maintenance
- Conformity to standards
- Customisation
 - Colours
 - Number of boxes
 - Roofs
 - Apparatus
- Assembly
- Overall views & drawings
- Appendices





Materials & surface treatments

Grips PVC hardness 50 ShA / Injection moulding.

Roof tightness Foam seals in EPDM
(ethylene propylene diene monomer).

Fittings Stainless steel A2 DIN 7991 standards.

- Steel S235 hot galvanised after manufacture (**central structure**), tubing 60x60mm 3mm thick.
- Steel S235 galvanised by electrolysis (**apparatus fastening plates**),
3 mm thick.
- Steel S235 treated according to our *Powder Blast* process which limits the use of heavy metal and offers a very high quality finish.

Metal parts

The stages in the *Powder Blast* Process: degreasing, sandblasting, polymerisation by gelification of the protective anticorrosion epoxy powder, polymerisation by infrared kiln-baking and thermal convection of the polyester-based finishing coat
(banner + roof crosspieces ex IPE), 60x60 5 mm thick
For more information, Cf. Appendices.

- Painted galvanised steel S355 (**IPE roof**).
- Steel S235 hot galvanised after manufacture and transparent polyurethane-based varnish (**apparatus**).
diameter 48.3, 3.2mm thick / diameter 33.7, 3.2mm thick / sheet metal 4mm thick.

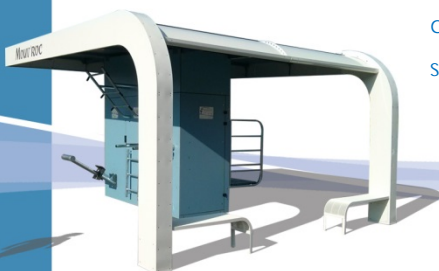



Materials & surface treatments

HPL cladding

High density laminate panels (13mm thick) exterior quality with motifs on both sides. They are made by stacking sheets of paper impregnated with thermo-reinforced resins (phenolic and melamine resins), pressed at high pressure (10MPa) at a temperature of 160°C.

An acrylic film provides additional protection against ultraviolet rays.

VIVIX panels are:

- **highly resistant to impacts and abrasion.**
- **resistant to ultraviolet rays** and weather conditions, and have been rigorously tested in accordance with the EN 438-6 and EN 438-2 standards, test methods 28 & 29.
- **Easy to maintain** and they can be **simply cleaned** with gentle detergent and water.
- **fireproof**, do not rot and do not crack.

The Formica Group production plants have been awarded Traceability Chain certification by the FSC® (Forest Stewardship Council). The network of participating plants is detailed in Certificate no. TTCOC-003588.

Additional information in the Appendices.

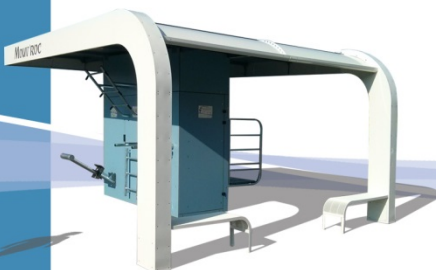



Materials & surface treatments

Information Panels

Panels in polycarbonate resistant to abrasion and UV, which combines the hardness of glass with the resistance to impacts of standard polycarbonate (in accordance with the ISO 527 standard).

Treated against yellowing and fading (in accordance with the DIN 5036 standard).

Inverted printing of the information (can in fact be seen with visual in the background of the Plexiglass cover).

Additional information in the Appendices.





Solidity of the structure / Maintenance

The solidity is assured

- by the robustness of the materials from which the structure and the apparatus are made
- by the installation of static rather than moving apparatus.

The option chosen when designing MOUV'ROC was to generate movement with the body and not by the mechanical movement of the apparatus (synonymous with wear and mechanical fatigue with intensive use of the apparatus).

Maintenance

is made easier owing to the design of MOUV'ROC

- A structure in galvanised steel
- HPL boards which are easily replaced
- Single unit apparatus forming a piece with the structure on which the fittings cannot be accessed

Conformity to standards

The Mouv'roc Fitness & Health Station and the information panels on the equipment comply with the standard

XP S52-904:2009





Guarantees

The guarantees covering MOUV'ROC are the following:

Against breakage:

- The apparatus has a **10-year** guarantee against breakage,
- The structure has a **10-year** guarantee against breakage,
- The HPL panels are guaranteed for **5 years**
- The information panels are guaranteed for **3 years**

Against corrosion:

- The galvanised metal parts have a **10-year** guarantee against corrosion, except when sited in the immediate vicinity of a coastline
- The galvanised metal parts painted with kiln-fired polyester powder are guaranteed for **5 years**, except when sited in the immediate vicinity of a coastline
- The information panels have a **5-year** guarantee against bad weather conditions excluding printing and except when sited in the immediate vicinity of a coastline

The following are excluded from the guarantees:

- Damage caused by vandalism (wilful damage, fire, etc.) or impacts or uses not consistent with normal conditions of use.
- Natural wear caused by intensive use of MOUV'ROC, notably on all contact zones between MOUV'ROC and the users.
- Wearing parts such as grips, rubber, and other contact parts, the synthetic ground coverings, any lighting.
- The fading of colours and wear of the surface treatments, caused by UV damage, sea mist, sandstorms, and extreme temperatures.
- Installations at very high altitude owing to their resistance to the weight of wet snow and installations close to the coast.
- The information stickers.

A maintenance contract can be agreed for the purposes of overseeing the MOUV'ROC as it ages and inspecting the structural elements, the apparatus and the wearing parts and to see to their replacement under financial terms and at frequencies to be decided.

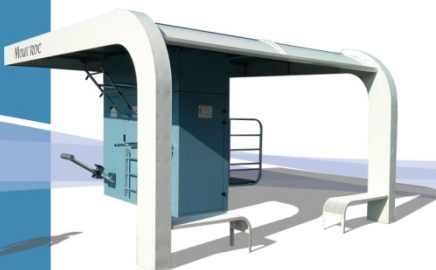



Customisation

The Mouv'roc Fitness & Health Station is modular:

The very design of Mouv'roc is based on a system of boxes. Three in number on the Jumbo version, they serve to support the attachment of the apparatus. If requested, it is possible

- to modulate the number of boxes (and therefore the size of the equipment).
- To choose various versions of the roof.
- To define the type and number of apparatus.

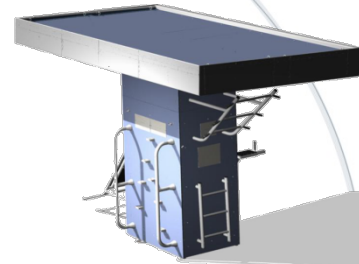

The Mouv'roc Fitness & Health Station can be customised:

If requested, it is possible

- To build in specific options such as lighting.
- To customise the messages to be placed on the roof banners.

A fuller range of signs can be installed on the internal side of the roof banners in order to show the various exercises available to users who do not possess a smartphone.

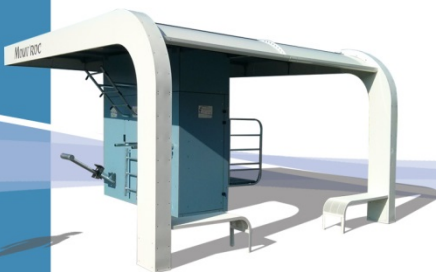



Customisation

The metal parts & the HPL panels on Mouv'roc can be customised*:

HPL Colour Wheel

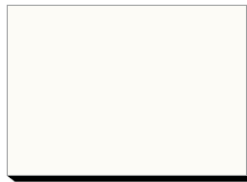

K1040 - Alpino



F7927 - Folkestone



F7940 - Spectrum Yellow



**F7884 - China Blue
(default colour)**



F4161 - Terracotta



K1238 - Carnaval



F6901 - Vibrant Green



F7967 - Hunter Green



F7969 - Navy Blue

*We would draw our customers' attention to the relevance of the choice of colours of the HPL panels for the box which will come into direct contact with the users. Too distinctive a colour may make Mouv'roc's apparatus uncomfortable.

RAL Colour Wheel

(metal parts)



- | | |
|------------------|----------|
| Mint green | RAL 6029 |
| Yellow green | RAL 6018 |
| Turquoise blue | RAL 5018 |
| Light blue | RAL 5012 |
| Gentian blue | RAL 5010 |
| Signal blue | RAL 5005 |
| Ultramarine blue | RAL 5002 |
| Ruby red | RAL 3003 |
| Traffic red | RAL 3020 |
| Signal orange | RAL 2010 |
| Melon yellow | RAL 1028 |
| Telegrey 4 | RAL 7047 |
| Telegrey 2 | RAL 7046 |





MOUV'ROC

Customisation Examples

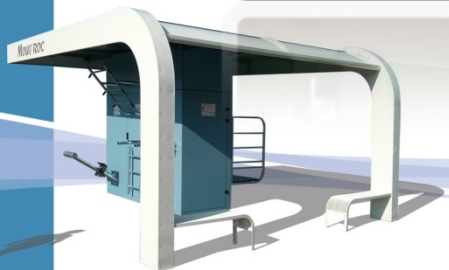



Mouv'ROC

Customisation Examples



Sign
options

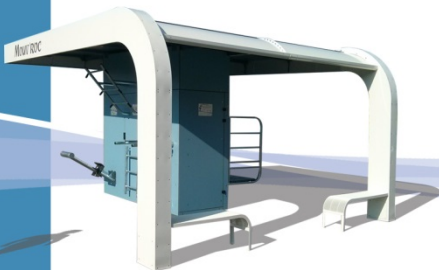



MOUV'ROC

Assembly

4 people + lifting apparatus (crane, forklift)

EASY INSTALLATION

- A concrete slab dosed at 350 kg/m^3 , 12 cm thick, drying time 21 days in accordance with DTU.
- Installation of MOUV'ROC Jumbo in 1 day.
- Easy to dismantle and re-assemble, as the unit has been designed with this in mind.

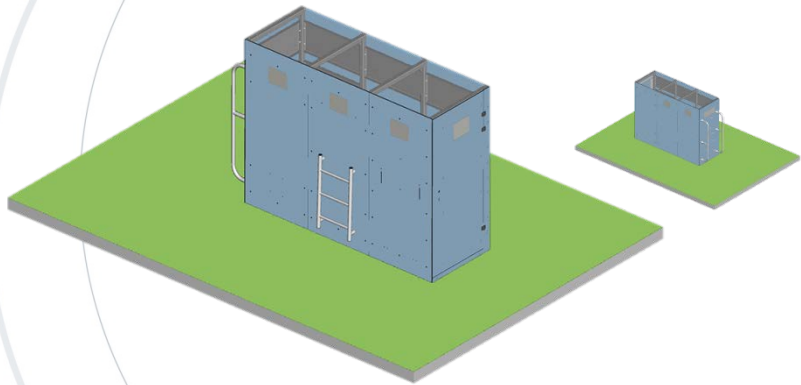

Assembling & mounting the central box

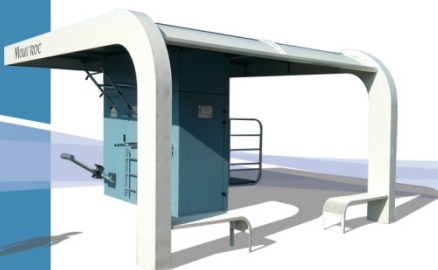
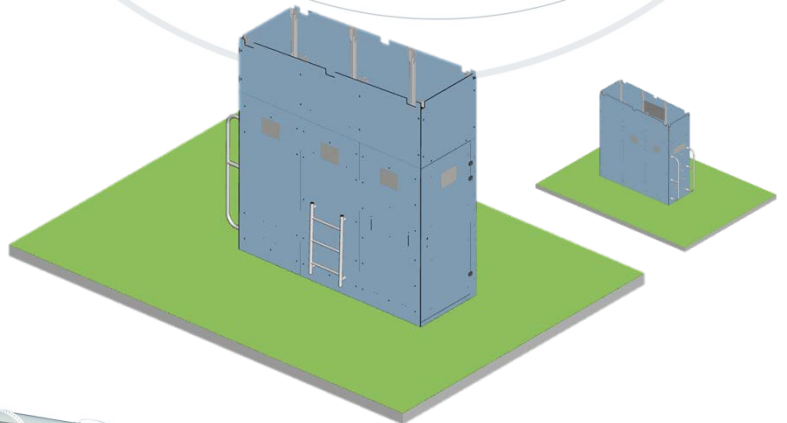

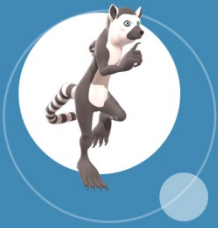

MOUV'ROC

Assembly

4 people + lifting apparatus (crane, forklift)

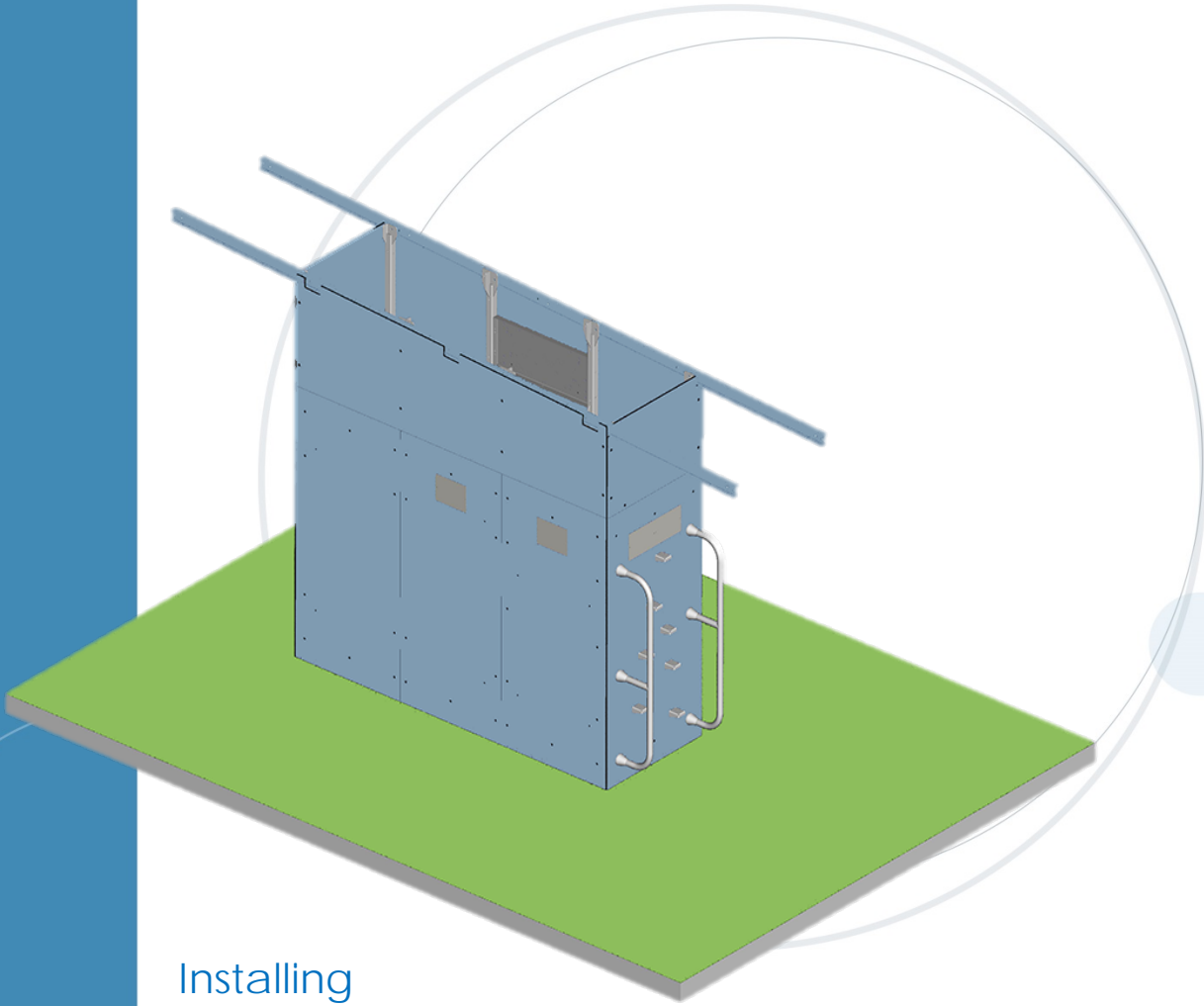

Installing
& mounting
the crosspieces

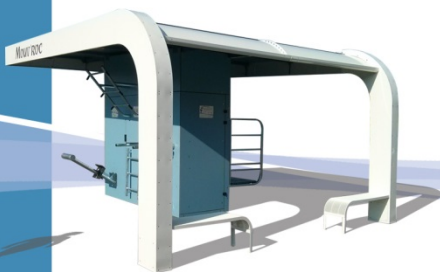



MouV'ROC

Assembly

4 people + lifting apparatus (crane, forklift)

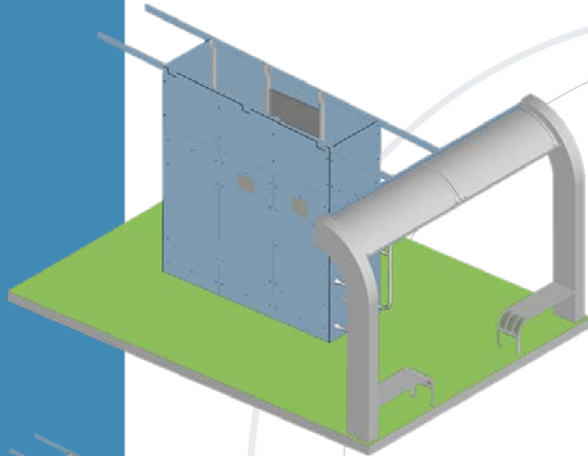

Assembling and mounting the framework & roof

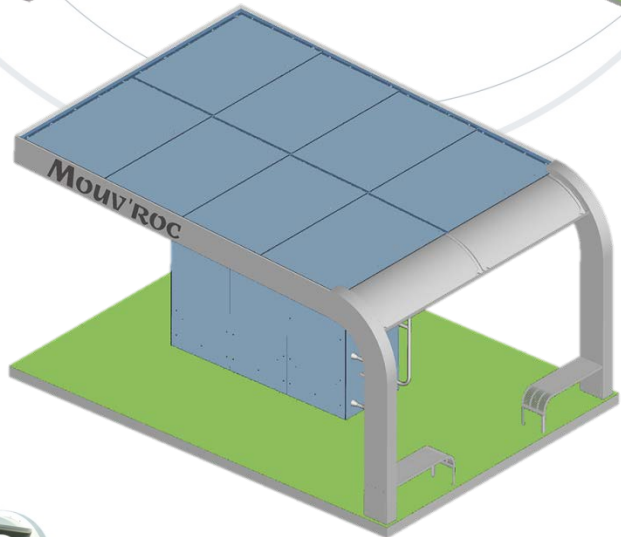
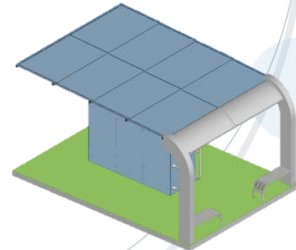
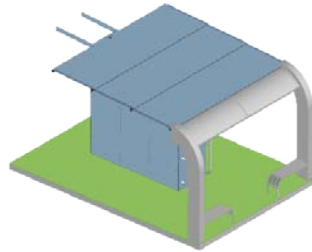
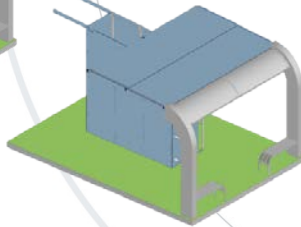
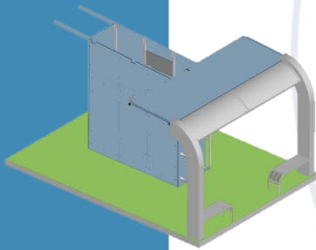



MOUV'ROC

Assembly

4 people + lifting apparatus (crane, forklift)

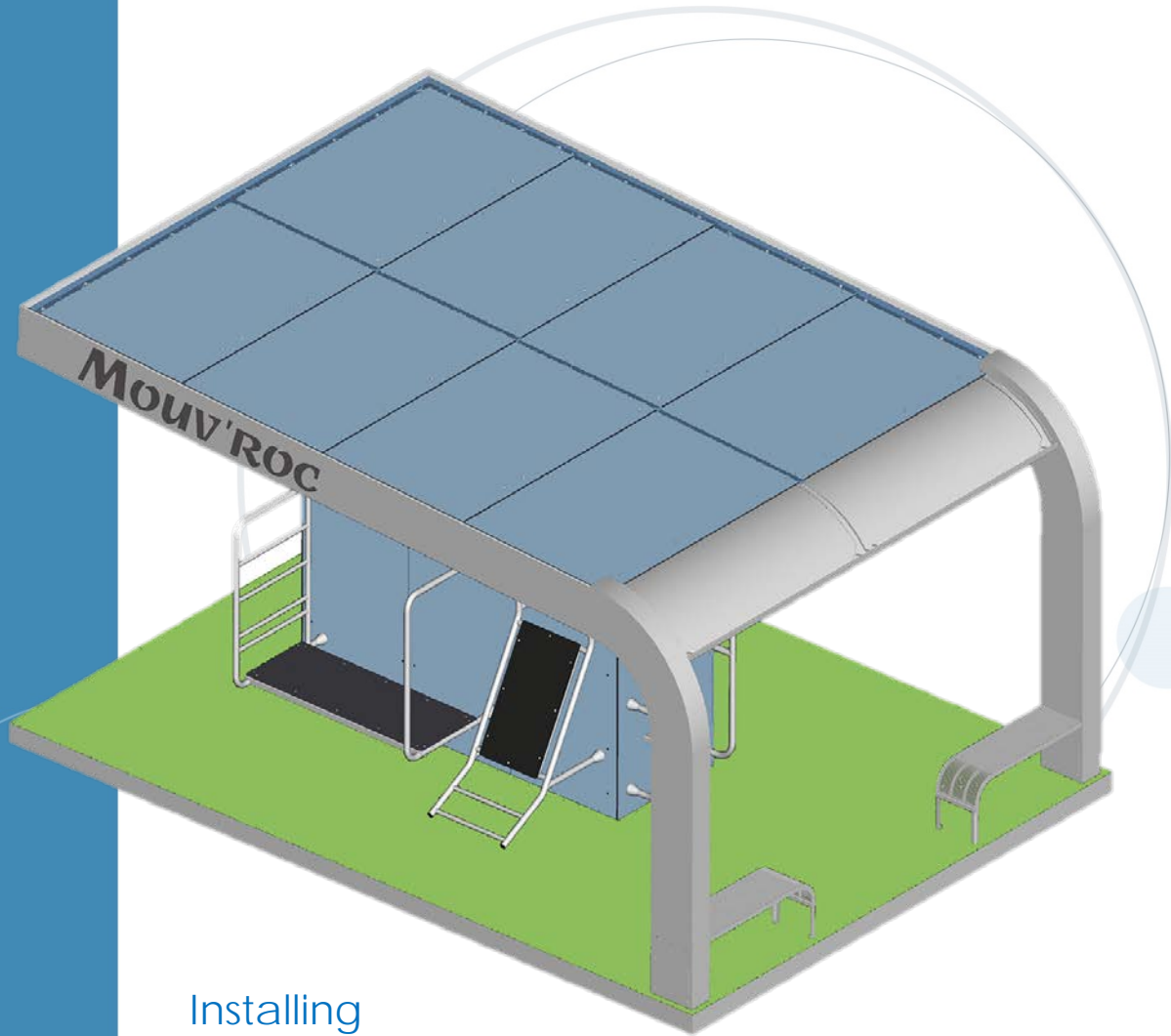

Installing
& mounting
the apparatus





Mouv'ROC

The apparatus

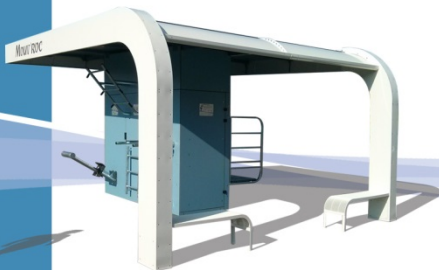
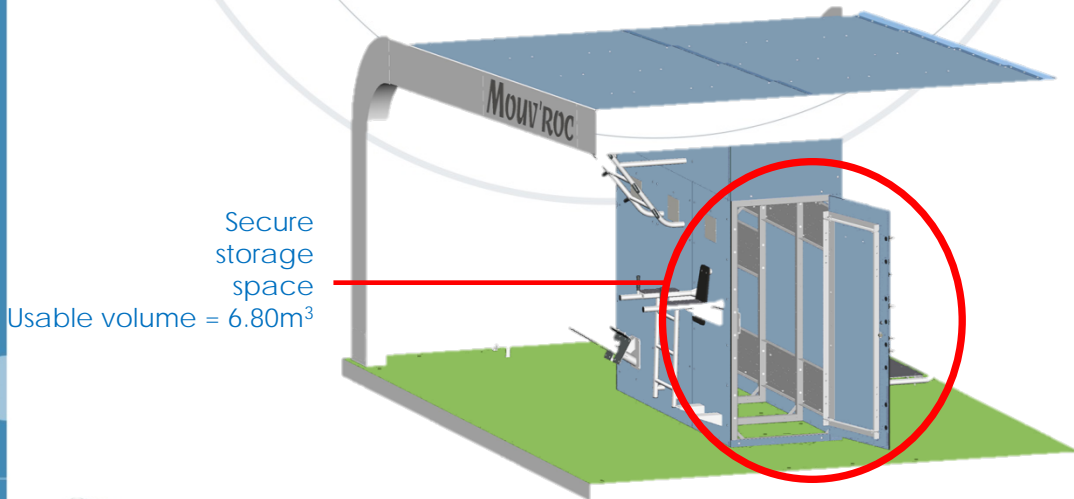
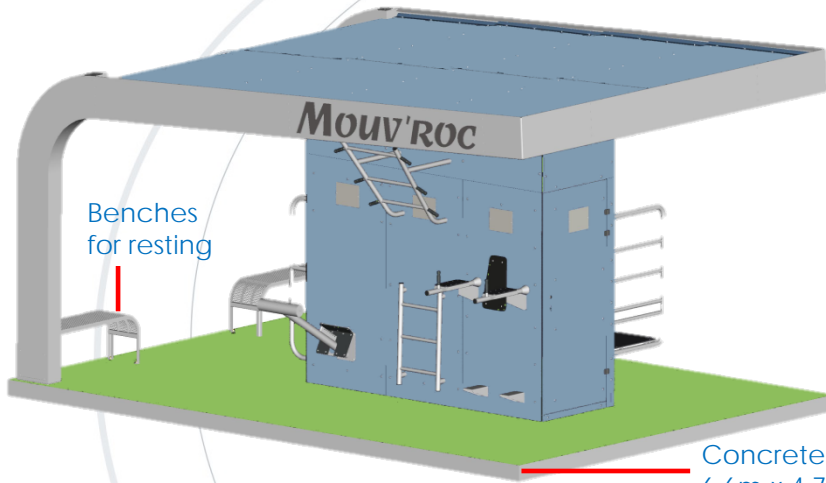



The apparatus

1. Seat
2. Ramp
3. Cleats
4. Vertical bars
5. Roller
6. Traction bar
7. Roman chair

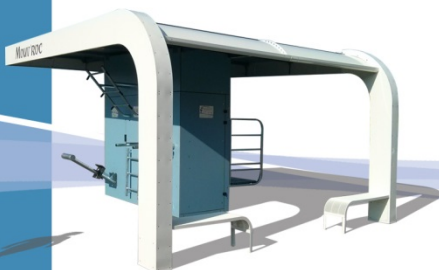
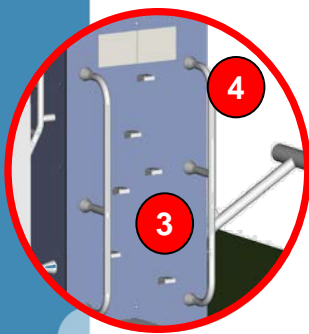
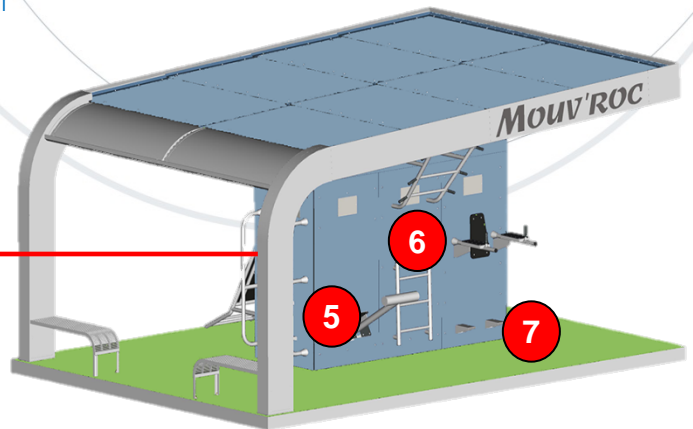
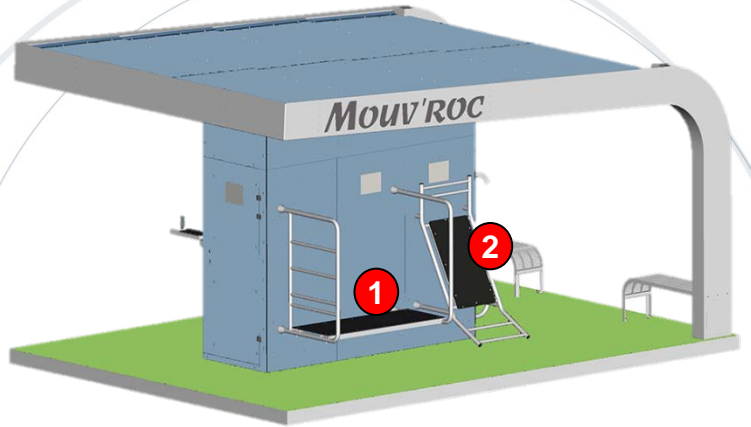



Drawings

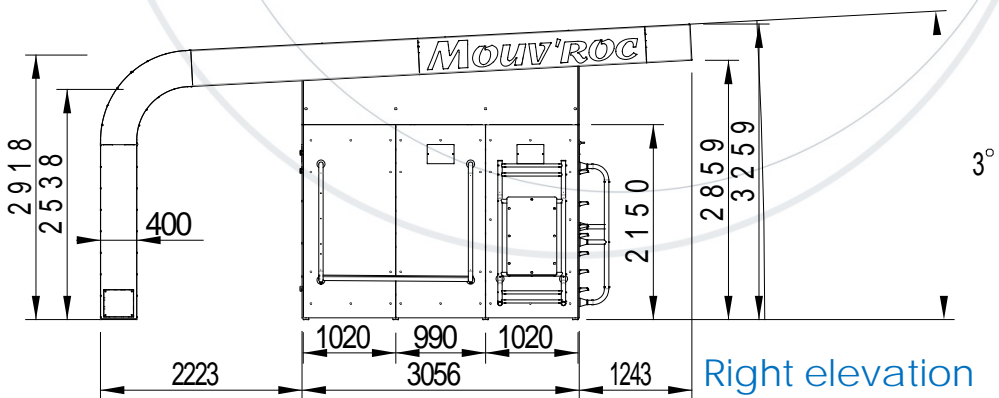
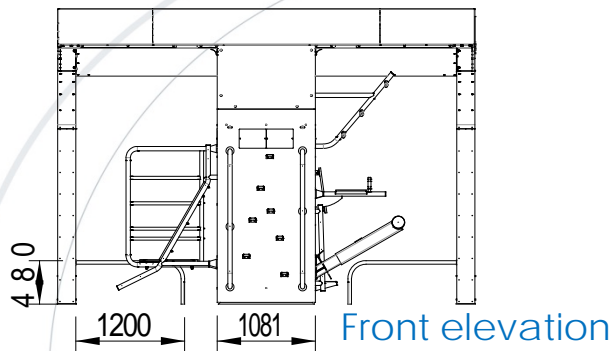



Drawings

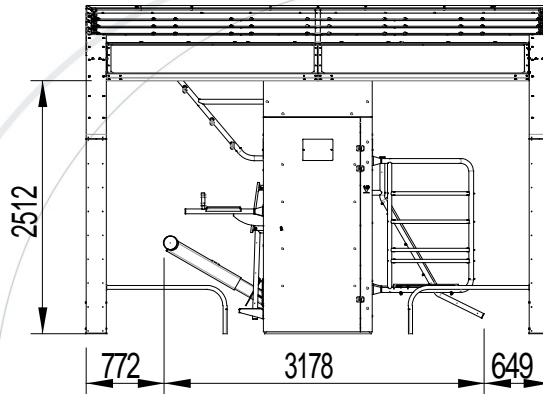

Back elevation

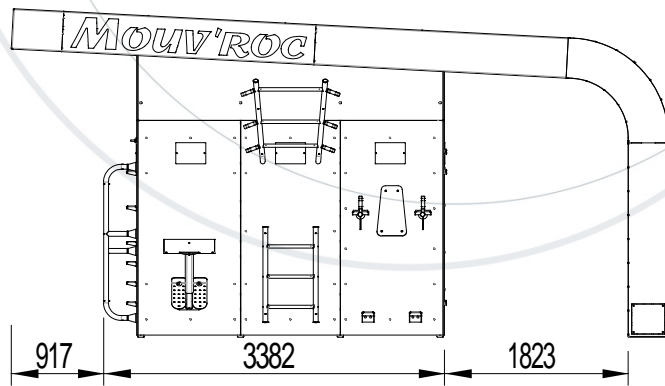

Left elevation

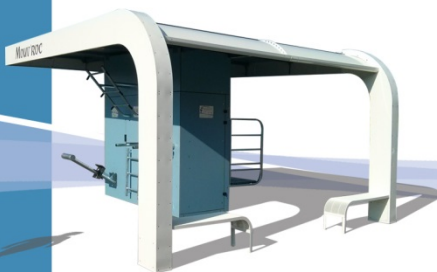



Drawings

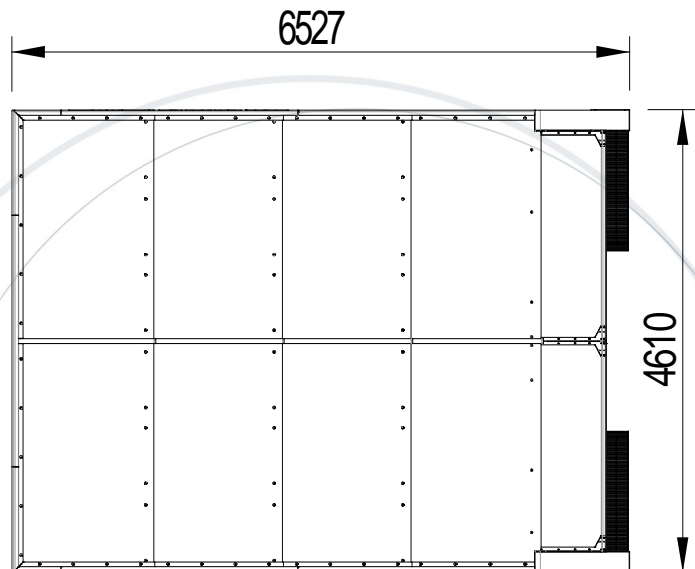

Top elevation

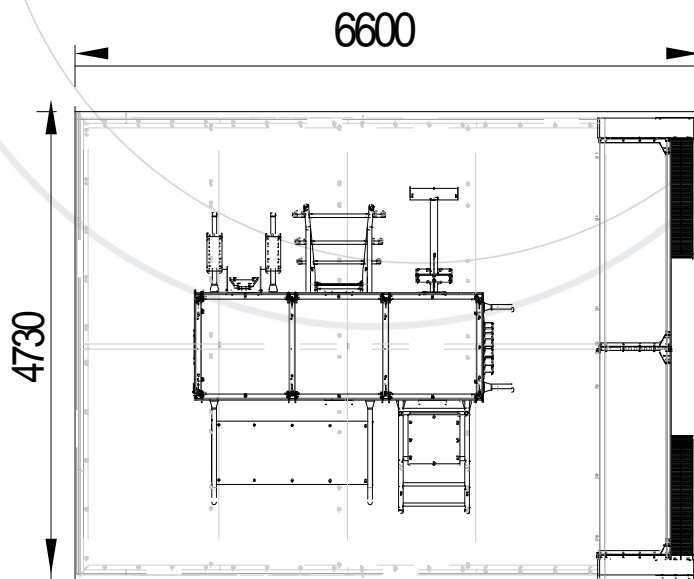

Top elevation with view
through roof
& concrete slab





MOUV'ROC

Appendices



PAINT TREATMENT

Sineu Graff : Intelligent Design
for the town of tomorrow

Sineu Graff, in tandem with professionals from the surface treatment and paint industry, has developed a surface treatment and finishing process intended for metal parts in steel, cast iron and aluminium.

Electro galvanisation

This is a zinc coating produced by the electrolysis of a solution containing Zn^{2+} ions.

This process is used to protect metal parts against corrosion.

Powder Blast

This process is installed in our factory and incorporates various applications done in a continuous process in order to guarantee optimum protection and optimum resistance of the paint on urban furniture.

► The various steps of POWDER BLAST

- Alkaline degreasing, followed by rinsing and meticulous drying
- Systematic powder blasting of all parts, followed by air blowing treatment
- Deposit of 90 μm of anticorrosion powder on an Epoxy base using an automated electrostatic process
- Polymerisation of this first coat of antirust protection by gelification at 140°C
- Deposit of 90 μm of polyester-based finishing powder according to the SINEU GRAFF colour wheel
- Polymerisation by infrared baking of this finishing coat followed by thermal convection at 200°C



Washing, degreasing, drying and blasting of parts



Automated electrostatic application



Oven baking the paint



Street Furniture

PAINT TREATMENT

Sineu Graff : Intelligent Design
for the town of tomorrow

➤ The aim of POWDER BLAST is to ensure:

Enhanced paint adhesion by faultless surface preparation, obtained by mechanical stripping of parts, incorporating degreasing immediately followed by blasting, which results in:

An optimum state of cleanliness:

- No dust, calamine, oil or grease, acid residues
- No micro-fissures on welds
- Degassing of parts from foundries

Mechanical adhesion of the paint by obtaining a surface condition of homogenous rugosity for every part.

➤ A very resistant antirust treatment is applied to the parts by:

The double coat of powder, antirust and finishing, applied to all parts, following surface preparation.

Enhanced adhesion of the finishing coat thanks to the gelification of the first epoxy-based coat, allowing interpenetration and therefore excellent adhesion of the polyester finishing coat to the epoxy polyester.

An excellent finish quality by:

The electrostatic powder application processes, checked by computer, guaranteeing:

- A homogenous paint thickness
- Extremely smooth surfaces



Street Furniture

PAINT TREATMENT

Sineu Graff : Intelligent Design
for the town of tomorrow

► Performance over time and respect for the environment:

An excellent performance over time:

- Tests performed in saline mist (ISO 7253 with surface damage) demonstrate excellent performance of the paint over time (1,000 hours with no notable propagation of corrosion).
- Quick drawing tests (ISO 6272-1) confirm the excellent adhesion of the paint even when seriously distorted.

A treatment that respects the environment:

- Our POWDER BLAST process does not use any products harmful to the environment or to our employees. Treatment is free of acids and heavy metals.
Powder residues are recovered by approved bodies that recycle them to be re-used in other activities.

“Coastal treatment”:

This surface treatment consists in galvanising the furniture and then applying two coats, the first being a primer, the second a finishing coat. NB: no guarantees are given on this type of treatment.



Street Furniture

Product description

VIVIX® solid phenolic, engineered exterior façade panels have a decorative surface on both sides. Robust and resilient, these rigid homogeneous panels are manufactured by Formica Group, using tough thermosetting resins reinforced with cellulose fibre for added strength and durability.

An acrylic overlay provides enhanced UV protection and VIVIX panels have been rigorously tested for severe use in accordance with EN 438-6, making them ideal for applications in ventilated rainscreen façades and other external building elements.

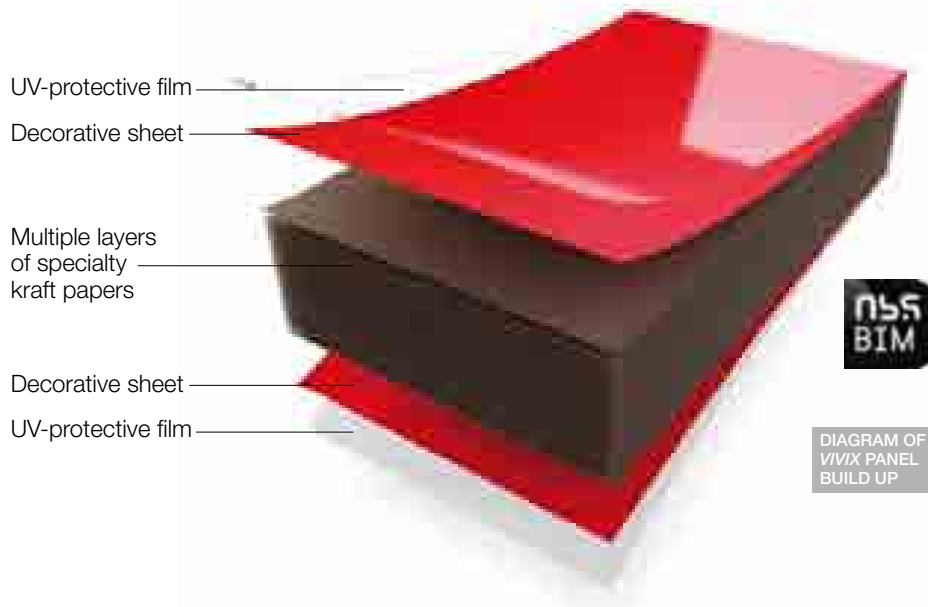

VIVIX architectural panels for ventilated rainscreen façades and other external building elements

Ventilated rainscreen façades with VIVIX panels are made up of the following elements:

- VIVIX panel in EDS or EDF grade
- Air cavity
- Thermal insulation
- Substructure, which transmits load to the structural wall
- Elements that attach panels to the substructure

VIVIX panel features and benefits:

- Broad range of decorative panels
- Optimal modulation using different sized panels
- UV resistant
- Durability
- Weather resistant
- Impact resistant
- VIVIX panels do not rot and are highly resilient against cracking
- Mechanical and chemical properties unchanged in testing at 180 °C
- Meets Fire Safety Standards. Does not melt or drip
- Easy to clean and maintain
- Dimensional stability and flatness
- Lightweight
- Low static electricity, does not attract dust
- Quick and easy to assemble
- Minimal maintenance
- No thermal bridge
- Limits heat loss in winter and the transmission of heat in summertime
- Overall lightweight substructure and façade

All features and benefits are subject to fair wear and tear and wilful damage, misuse or negligence by the buyer or user.

UV and weather resistance cannot be confirmed where the panels are located in places with climatic sunlight energy conditions exceeding those in EN 438-2, test methods 28 & 29.

These drawings indicate typical fixing arrangements on various supporting structures. Please contact your Formica Group representative for other possibilities. Any information or suggestions concerning applications, specification or compliance with regulations and standards is provided solely for your convenient reference and without any representation as to accuracy or suitability. The user must verify and test the suitability of any information or products for his or her particular purpose or specific application.

Technical drawings in this brochure should be considered as general examples of how VIVIX panels can be installed, there are other profiles and systems available in the market for ventilated façades which are not shown in this brochure. Consideration needs to be given to local circumstances, for example climate, wind load and local building regulations.

Makrolon® AR

Abrasion-resistant solid polycarbonate sheet



Your benefits:

- extreme impact strength
- good abrasion resistance
- excellent weathering resistance
- high clarity

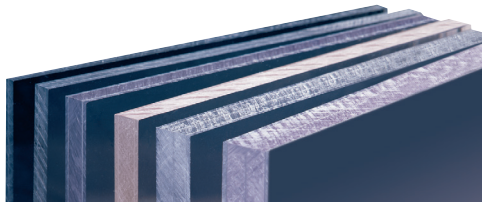

Makrolon® AR sheet is an abrasion and enhanced UV resistant polycarbonate sheet that offers glasslike hardness coupled with the impact strength of standard polycarbonate. Additionally, **Makrolon® AR** offers on both surfaces enhanced resistance against yellowing and hazing for an extended service life in high profile architectural glazing. **Makrolon® AR** has a 10-years warranty against breakage and 5-years warranty against delamination and weathering.

Applications:
 Typical applications for **Makrolon® AR** sheet include transparent sound barriers, school and hospital shelter glazing. **Makrolon® AR** is also used extensively in correctional and psychiatric facilities. Additionally, the product performs well for view windows and machine guards in harsh chemical environments. Due to its scratch-resistant coating, **Makrolon® AR** cannot be formed like other **Makrolon®** sheets.

	Test Conditions	Typical values ⁽¹⁾	Unit	Standard
PHYSICAL				
Density		1200	kg/m ³	ISO 1183-1
Water absorption saturation	water at 23 °C	0.30	%	ISO 62
Water absorption equilibrium	23 °C, 50% relative humidity	0.12	%	ISO 62
Refractive index	Procedure A	1.587	–	ISO 489
MECHANICAL				
Tensile modulus	1 mm/min	2350	MPa	ISO 527-1,-2
Yield stress	50 mm/min	> 60	MPa	ISO 527-1,-2
Yield strain	50 mm/min	6	%	ISO 527-1,-2
Nominal strain at break	50 mm/min	> 50	%	ISO 527-1,-2
Flexural modulus	2 mm/min	2350	MPa	ISO 178
Flexural strength	2 mm/min	90	MPa	ISO 178
Charpy impact strength	23 °C, unnotched	non-break	kJ/m ²	ISO 179-1eU
Charpy impact strength	23 °C, 3 mm, notched	80P	kJ/m ²	ISO 179-1eA
Izod impact strength	23 °C, 3.2 mm, notched	90P	kJ/m ²	ISO 180-A
Taber abrasion resistance	Δ haze after 100 cycles (500 g CS 10F) after 500 cycles	1 – 4 4 – 9	%	ASTM D1044 & ANSI Z26.1
THERMAL				
Vicat softening temperature	50 N, 50°C/h	148	°C	ISO 306
Thermal conductivity	23°C	0.20	W/(m.K)	ISO 8302
Coefficient of linear thermal expansion	23 to 55°C	0.65	10 ⁻⁴ /K	ISO 11359-1, -2
Temperature of deflection under load	1.80 Mpa	128	°C	ISO 75-1, -2
Temperature of deflection under load	0.45 Mpa	140	°C	ISO 75-1, -2

⁽¹⁾ These values are measured on injection molded samples, and are not intended for specification purposes.

Product Liability Clause: This information and our technical advice – whether verbal, in writing or by way of trials – are given in good faith but without warranty, and this also applies where proprietary rights of third parties are involved. Our advice does not release you from the obligation to verify the information currently provided – especially that contained in our safety data and technical information sheets – and to test products as to their suitability for the intended processes and uses. The application, use and processing of our products and the products manufactured by you on the basis of our technical advice are beyond our control and, therefore, entirely your own responsibility. Our products are sold in accordance with the current version of our General Conditions of Sale and Delivery.

Makrolon® AR

Abrasion-resistant solid polycarbonate sheet



Ideas, innovative, intelligent, interesting... Bayer MaterialScience i-line represents the next generation of quality products. This seal guarantees innovative and intelligent first-class solutions at all times for a multitude of requirements.

Light Transmission:

Test Method according to DIN 5036

The stated thicknesses are not all available as standard. Please ask us for more information.

The stated values are typical values only.

Light transmission in %	3	4	5	6	8	10	12	15
Makrolon® AR clear 8099	88	87	87	86	85	83	82	80
Makrolon® AR bronze 8850	50	50	50	50	50			

Available sizes:

Makrolon® AR is available in thicknesses of 3 – 15 mm and in the following sizes; other sizes, colors and sheet thicknesses on request.

Colors:

Makrolon® AR clear 8099

Makrolon® AR bronze 8850

Sizes:

3,000 x 2,000 mm

3,000 x 2,000 mm

Permanent Service Temperature:

The permanent service temperature without load is approx. 120°C.

Fire Rating (*):

Oxygen index (LOI) 28%, ISO 4589-2 Method A

Country	Standard	Rating	thickness	Colour
Germany	DIN 4102	B 2	3 – 12 mm	clear 8099
Germany	DIN 5510	S3 SR2 ST2	8 – 12 mm	clear 8099
USA	UL 94	V2 HB V0	0.75 - 1.4 mm ≥ 1.5 mm ≥ 10 mm	all colours all colours clear 8099

(*) Fire certificates are limited in time and scope, always check if the mentioned certificate is valid for the purchased Polycarbonate sheet type at the date of delivery. Polycarbonate sheets may change their fire behavior due to ageing and weathering. The indicated fire rating was tested on new / unweathered Product in accordance with the indicated fire classification standards.



Bayer MaterialScience

Bayer MaterialScience GmbH
 Otto-Hesse-Straße 19/T9, 64293 Darmstadt, Germany
 Tel. +49 6151 13 03-0
 Fax +49 6151 13 03-500

www.bayersheeteurope.com